

HOME VENTILATION WITH HEAT RECOVERY

M-WRG-S/Z-T(-F, -FC) and InControl pushbutton sensor

Connecting the ventilation unit M-WRG-S/Z-T(-F, -FC)
to the InControl pushbutton sensor

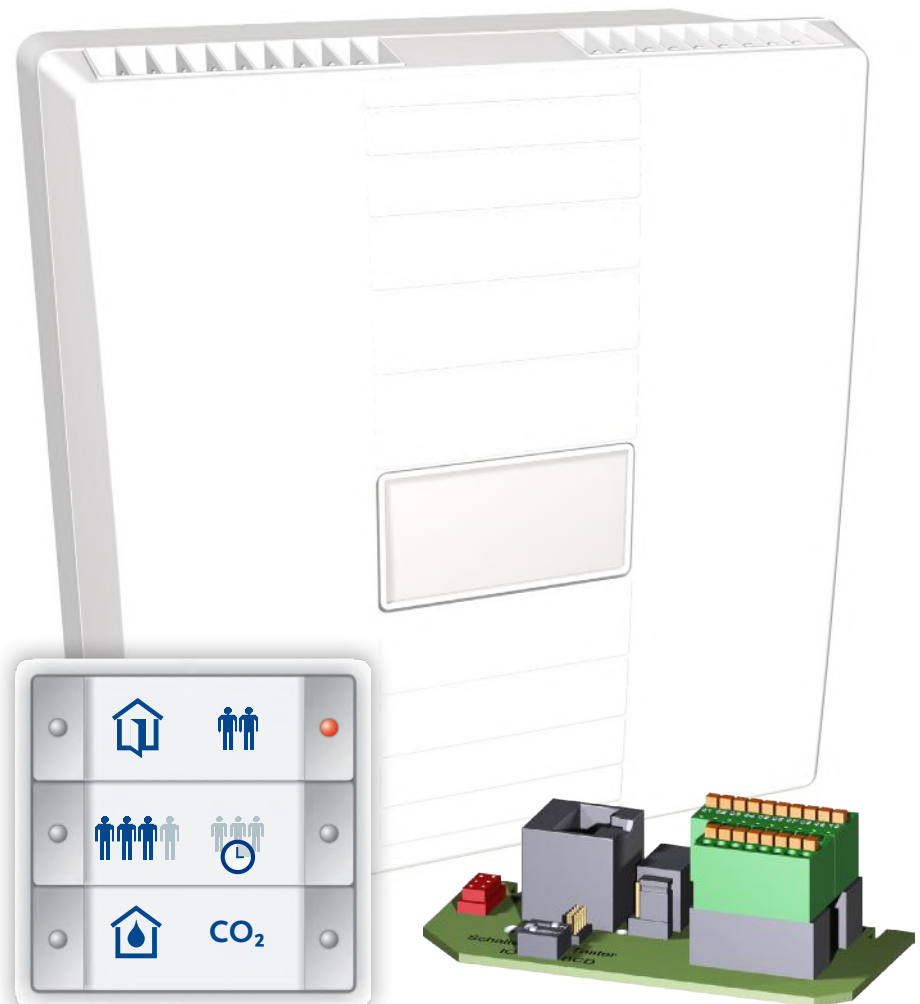

INSTALLATION MANUAL

Part no. 5301-09-01 Week 01/2017 EN



Contents

1	Introduction	3
1.1	Notes on this installation manual	3
1.2	Description	3
1.3	Target group	4
1.4	Revision index	4
1.5	Explanation of the symbols used	4
1.6	Supplementary documents	4
2	Safety instructions	4
2.1	Hazard classification	4
2.2	Notes on using the ventilation units safely	5
2.3	Intended use	5
3	Warranty and liability	5
4	Terminal assignment	5
4.1	Board with terminal blocks	5
4.2	InControl pushbutton sensor	6
4.2.1	Back panel with terminal blocks	6
4.2.2	Connection diagram	6
5	Connecting one ventilation unit	7
5.1	Connecting the InControl pushbutton sensor to the M-WRG-S/Z-T ventilation unit	7
5.2	Connecting the InControl pushbutton sensor to the M-WRG-S/Z-T-F ventilation unit	8
5.3	Connecting the InControl pushbutton sensor to the M-WRG-S/Z-T-FC ventilation unit ...	9
6	Connecting 2 to 5 ventilation units	10
6.1	Connecting the InControl pushbutton sensor to M-WRG-S/Z-T ventilation units	10
6.2	Connecting the InControl pushbutton sensor to M-WRG-S/Z-T-F ventilation units	11
6.3	Connecting the InControl pushbutton sensor to M-WRG-S/Z-T-FC ventilation units	11

1 Introduction

1.1 Notes on this installation manual



This installation manual contains important information that should be followed when connecting the M-WRG-S/Z-T, M-WRG-S/Z-T-F and M-WRG-S/Z-T-FC ventilation units to the InControl push-button sensor.

- ▶ Read all the instructions carefully before installing to avoid possible risks and mistakes.
- ▶ When installation is complete, give these instructions to the home owner, caretaker or property manager.
- ▶ These instructions are part of the product. Keep the instructions in a safe place for future reference.

WARNING

- ▶ Follow ALL danger and warning instructions and notes on precautionary measures.
- ▶ Read section „2 Safety instructions“ on page 4 carefully.

NOTE

- ▶ Also follow the M-WRG-S.../M-WRG-K... installation manual, part no. 5300-10-01, for installing the ventilation units.

1.2 Description

This manual describes how to connect the M-WRG-S/Z-T, M-WRG-S/Z-T-F and M-WRG-S/Z-T-FC ventilation units to the InControl pushbutton sensor.

Item	Part number
M-WRG-S/Z-T ventilation unit	5016-1-1
M-WRG-S/Z-T-F ventilation unit	5016-1-1-1
M-WRG-S/Z-T-FC ventilation unit	5016-1-1-2
InControl pushbutton sensor	5047-...

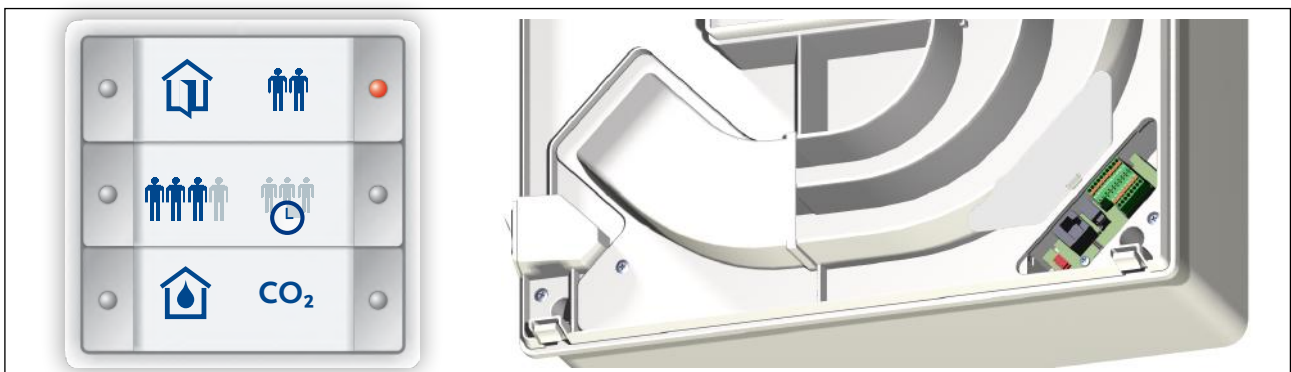

Fig. 1: InControl pushbutton sensor and board with terminal blocks in the ventilation unit

1.3 Target group

The activities described in this manual must only be carried out by technicians with the following qualifications:

- Training in the installation and commissioning of electrical devices
- Training in electrical hazards and the local safety requirements
- Knowledge of the relevant standards and directives
- Knowledge and observance of this document and all the safety instructions

1.4 Revision index

Edition	Manual	Date
2 nd edition	Installation manual M-WRG-S/Z-T(-F, -FC)	Week 01/2017 EN

1.5 Explanation of the symbols used

- ▶ This symbol indicates an action to be taken.
- This symbol indicates a list.

1.6 Supplementary documents

Manual	Part no.
Installation manual M-WRG-S.../M-WRG-K...	5300-10

2 Safety instructions

This manual contains notes that you must follow for your own personal safety and to avoid injury and damage to property. They are highlighted by warning triangles and are shown as follows according to the level of danger.

2.1 Hazard classification

DANGER

The signal word designates a hazard with a **high** degree of risk which, if it is not avoided, will result in death or severe injury.

WARNING

The signal word designates a hazard with a **medium** degree of risk which, if it is not avoided, will result in death or severe injury.

CAUTION

The signal word designates a hazard with a **low** degree of risk which, if it is not avoided, could result in minor or moderate injury.

NOTE

A note as used in this manual contains important information about the product or about a part of the manual to which particular attention should be paid.

2.2 Notes on using the ventilation units safely

CAUTION

- **Starting and using the ventilation unit**
 - ▶ Do not start up the ventilation unit until it is fully installed.
 - ▶ Always make sure that the cover is closed and locked in place before using the ventilation unit.

2.3 Intended use

- The intended use includes compliance with all the notes in the installation manual.
- The ventilation unit must not be operated without a filter.
- For any use contrary to the intended use, Meltem Wärmerückgewinnung GmbH & Co. KG shall accept no liability for any damage that may occur and offers no warranty that the components will work perfectly and correctly.

3 Warranty and liability

The warranty and liability shall be void if the ventilation unit or InControl pushbutton sensor is not connected as described in this installation manual.

4 Terminal assignment

4.1 Board with terminal blocks

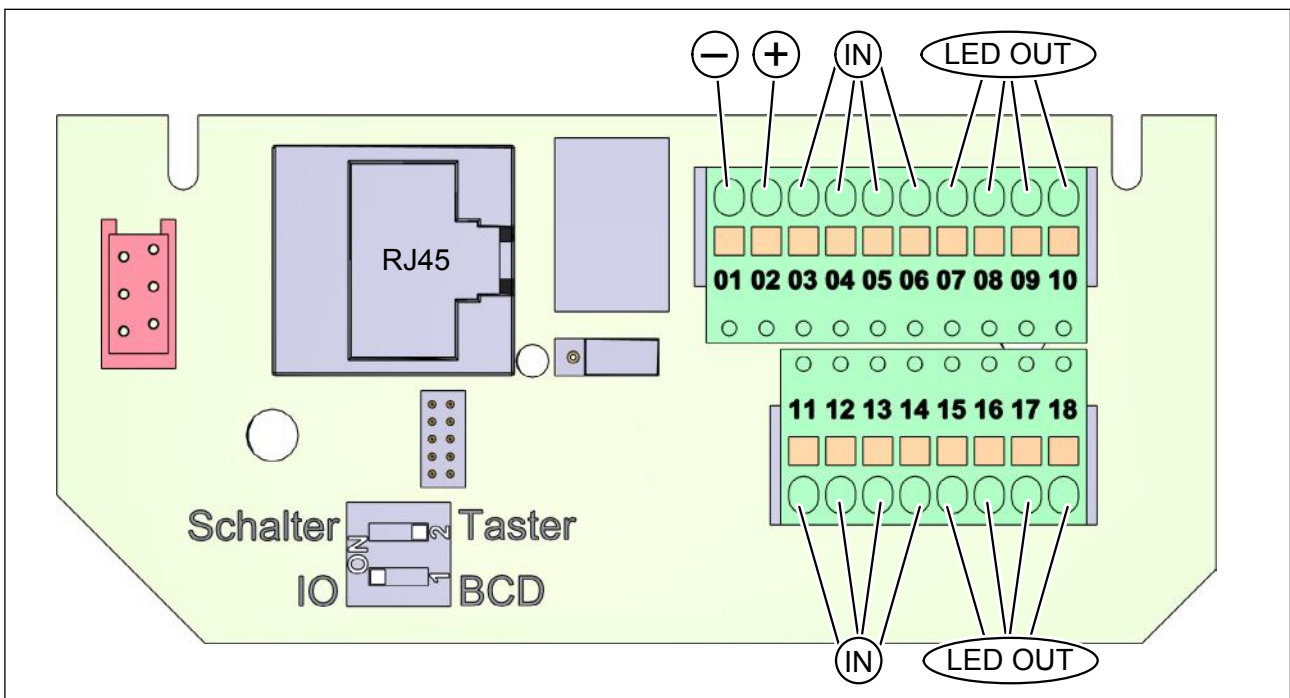

Fig. 2: Terminal assignment on the board with terminal blocks

4.2 InControl pushbutton sensor

4.2.1 Back panel with terminal blocks

Item	Designation
1	Terminal block for pushbuttons
2	Terminal block for LEDs
3	Smiley on the side of the terminal block for LEDs

NOTE

- ▶ Use the smiley (item 3 in Fig. 3) as an orientation guide. It is only in this position that the connections on the terminal blocks agree with the connections identified in the connection diagram (Fig. 4).

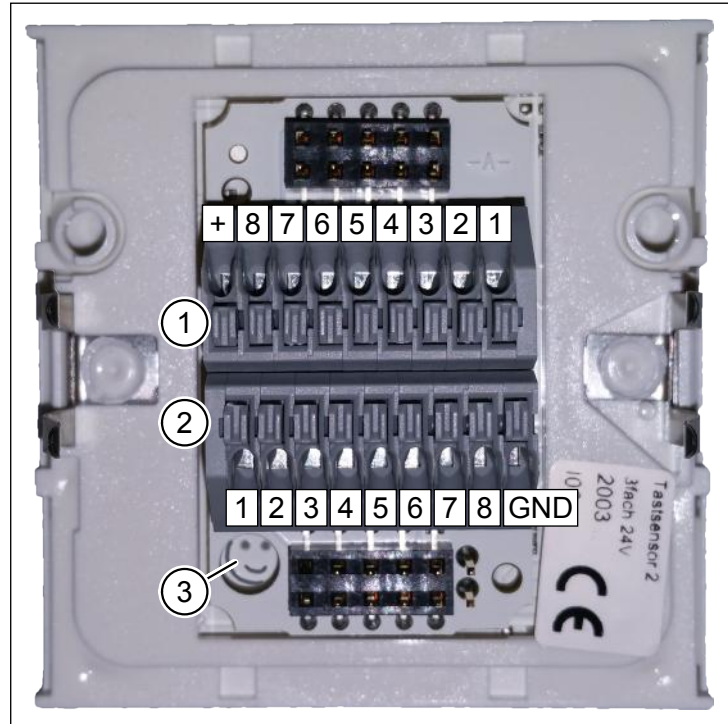

Fig. 3: Back panel with terminal blocks

4.2.2 Connection diagram

Item	Designation
1	Terminal block for pushbuttons
2	Terminal block for LEDs
3	Optional bridge for backlight

NOTE

- ▶ The InControl pushbutton sensor has a backlight that can be activated if required. Place a bridge (item 3 in Fig. 4) across terminals 7 and 8 of the terminal block for LEDs to supply 24 V DC to the backlight.

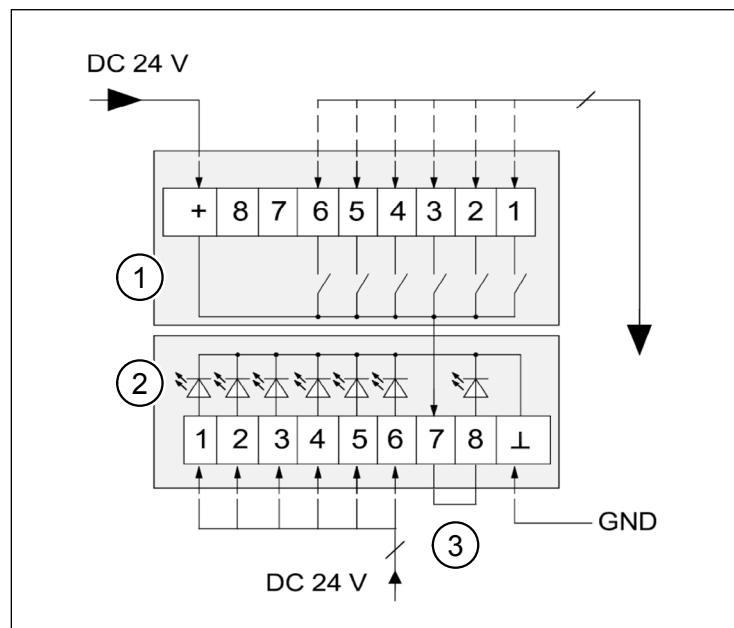

Fig. 4: InControl pushbutton sensor connection diagram

5 Connecting one ventilation unit

5.1 Connecting the InControl pushbutton sensor to the M-WRG-S/Z-T ventilation unit

- ▶ Use J-Y (St) Y 10x2x0.6 mm² / J-Y (St) Y 10x2x0.8 mm² for the wiring.
- ▶ After wiring, place the insert sheet (Fig. 5) in the InControl pushbutton sensor.

Terminal M-WRG-S/Z-T	Terminal blocks InControl pushbutton sensor		Wire colour	Function
	Pushbutton	LED		
1		GND		GND
2	+			+24 V DC
3	1			Reduced ventilation
4	2			Normal ventilation
5	3			Increased ventilation
6	4			Intensive ventilation
7		1		LED 1: reduced ventilation / flashes if there is a fault in the ventilation unit
8		2		LED 2: normal ventilation / flashes if there is a filter warning
9		3		LED 3: increased ventilation
10		4		LED 4: intensive ventilation
11	5			Supply air operation
12	6			Extract air operation
13				Unused
14				Unused
15		5		LED 5: supply air operation
16		6		LED 6: extract air operation
17				Unused
18				Unused

Table 1: Connecting the InControl pushbutton sensor to the M-WRG-S/Z-T ventilation unit

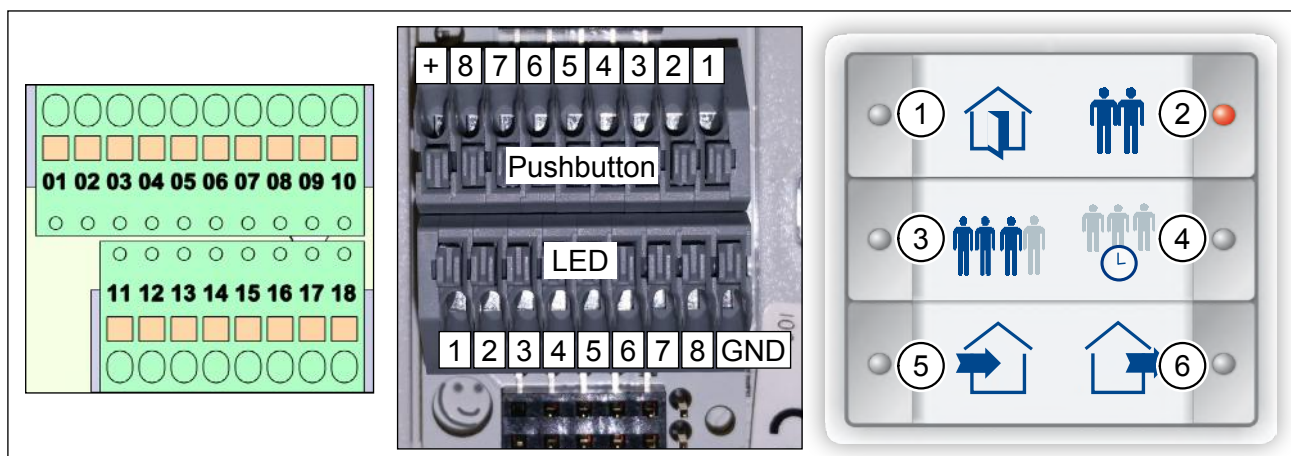

Fig. 5: Terminal blocks on M-WRG-S/Z-T, terminal blocks on InControl pushbutton sensor, M-WRG-S/Z-T insert sheet

5.2 Connecting the InControl pushbutton sensor to the M-WRG-S/Z-T-F ventilation unit

- ▶ Use J-Y (St) Y 10x2x0.6 mm² / J-Y (St) Y 10x2x0.8 mm² for the wiring.
- ▶ After wiring, place the insert sheet (Fig. 6) in the InControl pushbutton sensor.

Terminal M-WRG-S/Z-T-F	Terminal blocks InControl pushbutton sensor		Wire colour	Function
	Pushbutton	LED		
1		GND		GND
2	+			+24 V DC
3	1			Reduced ventilation
4	2			Normal ventilation
5	3			Increased ventilation
6	4			Intensive ventilation
7		1		LED 1: reduced ventilation / flashes if there is a fault in the ventilation unit
8		2		LED 2: normal ventilation / flashes if there is a filter warning
9		3		LED 3: increased ventilation
10		4		LED 4: intensive ventilation
11	6			Supply air operation
12				Unused
13	5			Humidity control
14				Unused
15		6		LED 6: supply air operation
16				Unused
17		5		LED 5: humidity control / flashes when supply air humidity > extract air humidity
18				Unused

Table 2: Connecting the InControl pushbutton sensor to the M-WRG-S/Z-T-F ventilation unit

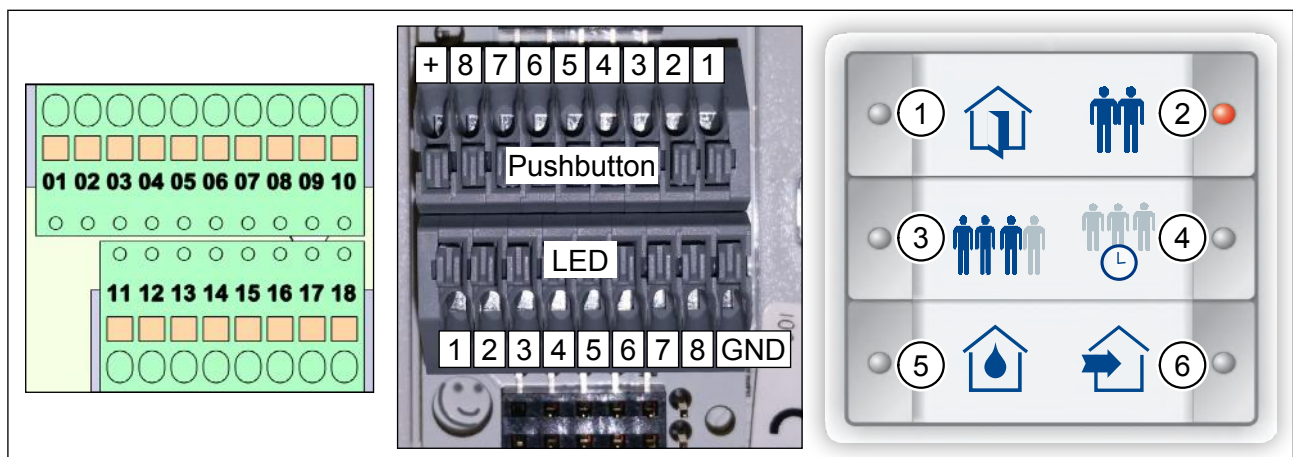

Fig. 6: Terminal blocks on M-WRG-S/Z-T-F, terminal blocks on InControl pushbutton sensor, M-WRG-S/Z-T-F insert sheet

5.3 Connecting the InControl pushbutton sensor to the M-WRG-S/Z-T-FC ventilation unit

- ▶ Use J-Y (St) Y 10x2x0.6 mm² / J-Y (St) Y 10x2x0.8 mm² for the wiring.
- ▶ After wiring, place the insert sheet (Fig. 7) in the InControl pushbutton sensor.

Terminal M-WRG-S/Z-T-FC	Terminal blocks InControl pushbutton sensor		Wire colour	Function
	Pushbutton	LED		
1		GND		GND
2	+			+24 V DC
3	1			Reduced ventilation
4	2			Normal ventilation
5	3			Increased ventilation
6	4			Intensive ventilation
7		1		LED 1: reduced ventilation / flashes if there is a fault in the ventilation unit
8		2		LED 2: normal ventilation / flashes if there is a filter warning
9		3		LED 3: increased ventilation
10		4		LED 4: intensive ventilation
11				Unused
12				Unused
13	5			Humidity control
14	6			Mixed gas/CO ₂ control
15				Unused
16				Unused
17		5		LED 5: humidity control / flashes when supply air humidity > extract air humidity
18		6		LED 6: mixed gas/CO ₂ control

Table 3: Connecting the InControl pushbutton sensor to the M-WRG-S/Z-T-FC ventilation unit

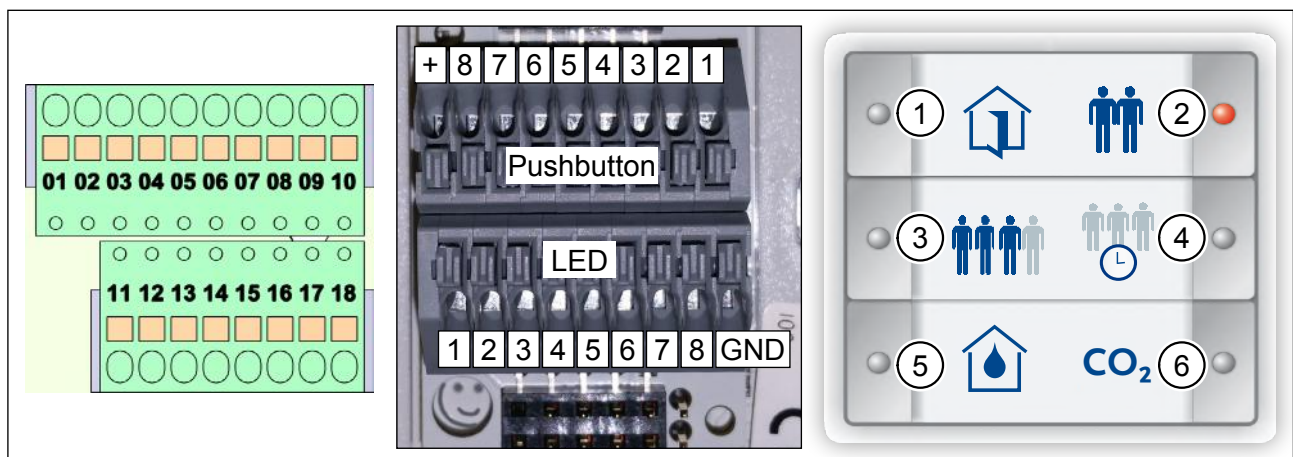

Fig. 7: Terminal blocks on M-WRG-S/Z-T-FC, terminal blocks on InControl pushbutton sensor, M-WRG-S/Z-T-FC insert sheet

6 Connecting 2 to 5 ventilation units

Up to five ventilation units can be controlled with one InControl pushbutton sensor. The following conditions must be met:

- The ventilation units must all be of the same type.
- All the ventilation units that are connected to the same InControl pushbutton sensor should be located in the same room.
- If possible, the control cables should be arranged and connected in a star configuration (see Fig. 8) from the ventilation units to the InControl pushbutton sensor.
- The cable between the ventilation unit and InControl pushbutton sensor should be no more than 15 m long.
- Ventilation unit 1 (master) must always be switched on. It generates the feedback for the LED on the InControl pushbutton sensor. Ventilation units 2 to 5 (slaves) only respond to switching commands from the InControl sensor.

NOTE

- ▶ Connect “+” only to the first ventilation unit (master).
- ▶ Connect “GND” to all the ventilation units (master + slaves).

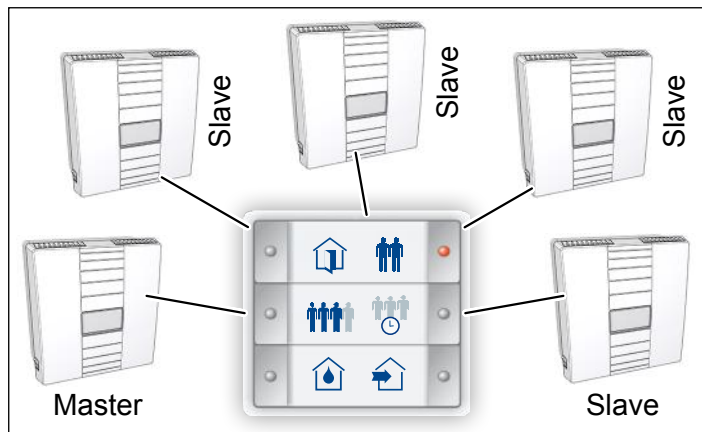

Fig. 8: Connecting the ventilation units in a star configuration

6.1 Connecting the InControl pushbutton sensor to M-WRG-S/Z-T ventilation units

Terminal blocks InControl pushbutton sensor		Number Ventilation unit M-WRG-S/Z-T				
Pushbutton	LED	1 (master)	2 (slave)	3 (slave)	4 (slave)	5 (slave)
+		2				
1		3	3	3	3	3
2		4	4	4	4	4
3		5	5	5	5	5
4		6	6	6	6	6
5		11	11	11	11	11
6		12	12	12	12	12
	GND	1	1	1	1	1
	1	7				
	2	8				
	3	9				
	4	10				
	5	15				
	6	16				

Table 4: Connecting the InControl pushbutton sensor to M-WRG-S/Z-T ventilation units

6.2 Connecting the InControl pushbutton sensor to M-WRG-S/Z-T-F ventilation units

Terminal blocks InControl pushbutton sensor		Number M-WRG-S/Z-T-F ventilation unit				
Pushbutton	LED	1 (master)	2 (slave)	3 (slave)	4 (slave)	5 (slave)
+		2				
1		3	3	3	3	3
2		4	4	4	4	4
3		5	5	5	5	5
4		6	6	6	6	6
5		13	13	13	13	13
6		11	11	11	11	11
	GND	1	1	1	1	1
	1	7				
	2	8				
	3	9				
	4	10				
	5	17				
	6	15				

Table 5: Connecting the InControl pushbutton sensor to M-WRG-S/Z-T-F ventilation units

6.3 Connecting the InControl pushbutton sensor to M-WRG-S/Z-T-FC ventilation units

Terminal blocks InControl pushbutton sensor		Number M-WRG-S/Z-T-FC ventilation unit				
Pushbutton	LED	1 (master)	2 (slave)	3 (slave)	4 (slave)	5 (slave)
+		2				
1		3	3	3	3	3
2		4	4	4	4	4
3		5	5	5	5	5
4		6	6	6	6	6
5		13	13	13	13	13
6		14	14	14	14	14
	GND	1	1	1	1	1
	1	7				
	2	8				
	3	9				
	4	10				
	5	17				
	6	18				

Table 6: Connecting the InControl pushbutton sensor to M-WRG-S/Z-T-FC ventilation units



We have checked the content of this publication for conformity with the unit described in it. There may nevertheless still be differences, so we cannot guarantee complete accuracy.

The information in this publication is regularly checked and any necessary corrections are made in the subsequent editions.

Copyright © Meltem Wärmerückgewinnung GmbH & Co. KG

We reserve the right to make changes.

Meltem Wärmerückgewinnung GmbH & Co. KG

Am Hartholz 4
D-82239 Alling
Germany

Tel. +49 (0)8141 404179-0
Fax +49 (0)8141 404179-9
Internet: www.meltem.com
Email: info@meltem.com



Go to
Meltem download area