

HOME VENTILATION WITH HEAT RECOVERY

M-WRG-II M-U² installation kit

for integrating the M-WRG-II ventilation unit series
into the wall in solid walls and frame constructions

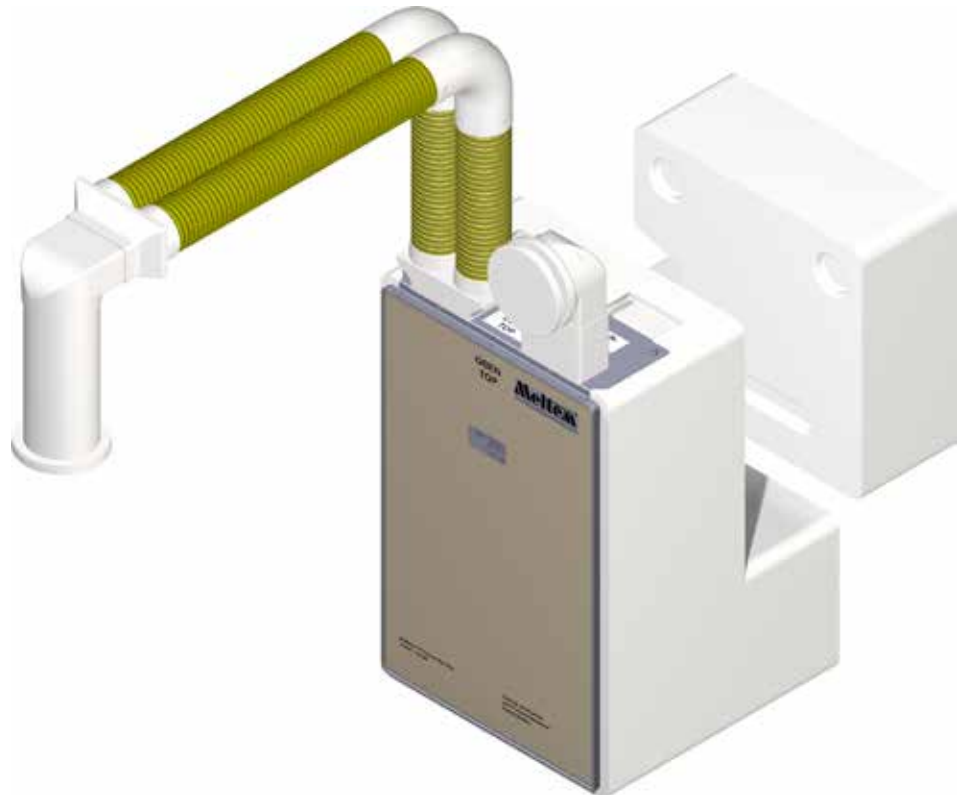

INSTALLATION MANUAL

Part no. 744003EN Week 30/2021 EN



Contents

1	Introduction	5
1.1	Notes on this installation manual	5
1.2	Description	5
1.3	Target group	6
1.4	Nameplates	6
1.5	Storage	6
1.6	Revision index	7
1.7	Explanation of the symbols used	7
1.8	Supplementary documents	7
2	Safety instructions	8
2.1	Hazard classification	8
2.2	Notes on using the ventilation units safely	8
2.2.1	Fire protection	8
2.2.2	Operation with fireplaces	8
2.2.3	Installation in wet areas	9
2.2.4	Condensate drain	9
2.2.5	Starting and using the ventilation unit	9
2.3	Notes on using the ventilation units	9
2.4	Note on use in conjunction with room air conditioners	10
2.5	Intended use	10
3	Planning notes	11
3.1	Positioning the ventilation unit indoors	11
3.2	Unrestricted access to the ventilation unit	12
3.3	Additional planning notes for this installation kit	12
3.3.1	Fire safety and soundproofing	12
3.3.2	Flat ductwork	13
3.3.3	Flexible pipes	13
3.4	Retrospectively flush-mounting the installation kit	13
3.5	Electrical connection	14
3.6	Special notes for installation in solid walls	14
3.7	Special notes for installation in frame constructions	14
3.7.1	Planning example for installing the installation kit in a frame construction with a framing member thickness of 160 mm	15
4	Warranty and liability	16
4.1	Warranty	16
4.2	Liability	16
5	Items supplied	17
5.1	M-WRG-II M-U ² installation kit, part no. 712000	17
5.2	Options	17
5.3	Installation materials required	17
6	Dimensions of the installation kit	18

7	General installation instructions	19
8	Installing the installation kit in a solid wall	19
8.1	Tools and equipment required	19
8.2	Breaking through the wall	20
8.2.1	Planning the wall breakthrough for new builds	20
8.2.2	Breaking through an existing wall	20
8.3	Chasing out channels for flat ductwork or flexible pipes	21
8.3.1	Chasing out channels for two flat ductwork connections (single room version)	21
8.3.2	Chasing out channels for connecting flat ductwork (multi-room version)	22
8.3.3	Chasing out channels for connecting flexible pipes (multi-room version)	23
8.4	Chasing out channels for connecting cables	24
8.5	Running the mains and control cables	25
8.5.1	Cable types	26
8.5.2	External control input	26
8.5.3	Option M-WRG-II O/EGG-AUS	27
8.6	Inserting the wall box	28
8.7	Inserting the protective cover and plaster cover	28
8.8	Fixing the wall box	28
8.9	Filling gaps around the wall box with foam	29
8.10	Inserting flat ductwork into channels	30
8.11	Cutting flexible pipes to length	30
8.12	Inserting flexible pipes into the flexible pipe connection	31
8.13	Fixing the connections for flat ductwork/flexible pipe to the wall box	31
8.14	Plastering the installation kit and flat ductwork / flexible pipes on the inside	32
8.15	Condensate drain on the exhaust air pipe	33
8.16	Aligning the wall box on the outside before plastering	34
8.16.1	If the solid wall is less than 42.5 cm thick	34
8.16.2	If the solid wall is more than 42.5 cm thick	34
8.17	Plastering the installation kit on the outside	35
8.18	Preparing the installation kit for connecting the ventilation pipes	36
8.19	Cutting ventilation pipes to length	36
8.20	Inserting and fixing the ventilation pipes	37
8.21	Sealing ventilation pipes on external wall	38
8.22	Attaching the outer wall terminal	38
9	Installing the installation kit in a frame construction	39
9.1	Tools and equipment required	39
9.2	Creating a mount for the installation kit in a frame construction	40
9.3	Sawing channels for flat ductwork or flexible pipes	41
9.4	Running the mains and control cables	42
9.4.1	Cable types	43
9.4.2	External control input	44
9.4.3	Option M-WRG-II O/EGG-AUS	45
9.5	Inserting and fixing the wall box	46
9.6	Inserting the protective cover and plaster cover	47
9.7	Filling gaps around the wall box with insulating material	48
9.8	Connecting the wall box to the vapour barrier	48
9.9	Inserting flat ductwork into channels	49

9.10	Cutting flexible pipes to length	49
9.11	Inserting flexible pipes into the flexible pipe connection	50
9.12	Fixing the connections for flat ductwork/flexible pipe to the wall box	50
9.13	Cladding the installation kit and flat ductwork / flexible pipes on the inside	51
9.14	Condensate drain on the exhaust air pipe	52
9.15	Aligning the wall box on the outside before plastering	53
9.15.1	If the wall is less than 42.5 cm thick	53
9.15.2	If the wall is more than 42.5 cm thick	53
9.16	Plastering the installation kit on the outside	54
9.17	Preparing the installation kit for connecting the ventilation pipes	55
9.18	Cutting ventilation pipes to length	55
9.19	Inserting and fixing the ventilation pipes	56
9.20	Sealing ventilation pipes on external wall	57
9.21	Attaching the outer wall terminal	57
10	Installing the ventilation unit	58
11	Installation example for installation in a solid wall	58

1 Introduction

1.1 Notes on this installation manual



This installation manual contains important information that should be followed when installing the M-WRG-II M-U² installation kit for the M-WRG-II series of ventilation units.

- ▶ Read all the instructions carefully before installing the kit to avoid possible risks and mistakes.
- ▶ When assembly is complete, give these instructions to the home owner, caretaker or property manager.
- ▶ These instructions are part of the product. Keep the instructions in a safe place for future reference.

⚠ WARNING

- ▶ Follow ALL danger and warning instructions and notes on precautionary measures.
- ▶ Read chapters 2 “Safety instructions” on page 8 and 3 “Planning notes” on page 11 carefully.

1.2 Description

This manual describes how to flush-mount the M-WRG-II M-U² installation kit (item 1 in Fig. 1) in solid walls and frame constructions. This installation kit is used to integrate ventilation units from the M-WRG-II series fully into the wall. Two flat ductwork connections **or** two flexible pipe connections **or** one flat ductwork connection and one flexible pipe connection may be used in the extract air and supply air openings. In solid constructions, if a complete wall aperture is planned for the installation kit in a new build, for example, or if a complete wall breakthrough is planned for a retrofit, the optional filler piece M-WRG-II M/Fü (item 2 in Fig. 1) can be used to pack out the wall. If required, the filler piece can be used in the same way in a frame construction.

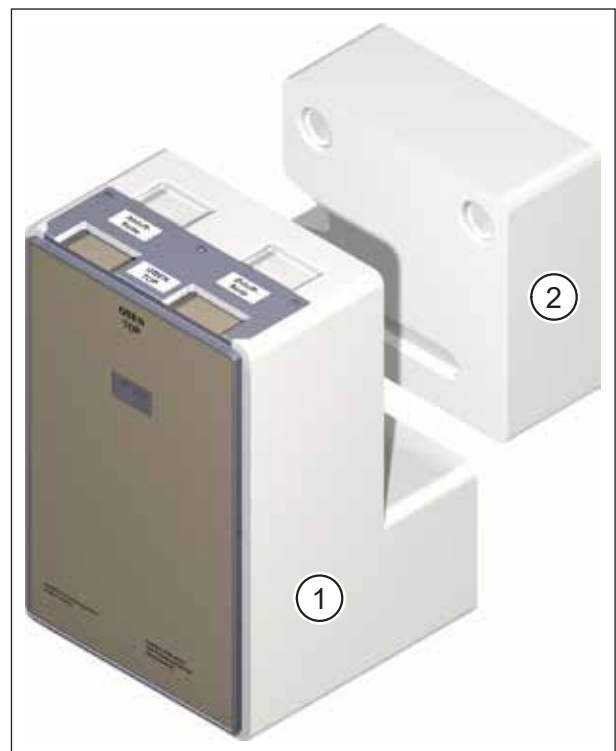

Fig. 1: Installation kit M-WRG-II M-U² and optional filler piece M-WRG-II M/Fü

1.3 Target group

The activities described in this manual must only be carried out by specialised personnel with the following qualifications:

- Training in the installation and commissioning of electrical devices
- Training in electrical hazards and the local safety requirements
- Knowledge of the relevant standards and directives
- Knowledge and observance of this document and all the safety instructions

1.4 Nameplates

The nameplates are attached in two places:

- on the plaster cover (item 1 in Fig. 2)
- beside the cable inlet for the mains and control cables (item 1 in Fig. 3)



Fig. 2: Nameplate on the plaster cover



Fig. 3: Nameplate on wall box

1.5 Storage

- ▶ Store the installation kit in its original packaging in a dry place where the temperature ranges between 0 °C and +40 °C.

1.6 Revision index

Edition	Manual	Date
5 th edition	Installation manual M-WRG-II M-U ²	Week 30/2021 EN

1.7 Explanation of the symbols used

- ▶ This symbol indicates an action to be taken.
- This symbol indicates a list.

1.8 Supplementary documents

Manual	Part no.
Installation manual for M-WRG-II ventilation units	744004EN
Installation manual for outer wall terminals M-WRG-II ES, M-WRG-II KSR	744005EN
Installation manual for window reveal installation kit (in preparation)	744006EN
Operating instructions for M-WRG-II P (-F, -FC), M-WRG-II E (-F, -FC) ventilation units	744007EN

Table 1: Supplementary documents

2 Safety instructions

This manual contains notes that you must follow for your own personal safety and to avoid injury and damage to property. They are highlighted by warning triangles and are shown as follows according to the level of danger.

2.1 Hazard classification

DANGER

The signal word designates a hazard with a **high** degree of risk which, if it is not avoided, will result in death or severe injury.

WARNING

The signal word designates a hazard with a **medium** degree of risk which, if it is not avoided, will result in death or severe injury.

CAUTION

The signal word designates a hazard with a **low** degree of risk which, if it is not avoided, could result in minor or moderate injury.

NOTICE

A note as used in this manual contains important information about the product or about a part of the manual to which particular attention should be paid.

2.2 Notes on using the ventilation units safely

2.2.1 Fire protection

Follow the generally applicable fire safety requirements when planning and installing the unit.

2.2.2 Operation with fireplaces

- When M-WRG-II ventilation units are used in conjunction with fireplaces, an additional safety device (underpressure or differential pressure monitor) is needed to monitor operation and to switch off the (230 V) power supply to the units when necessary.
- Follow the requirements of the German Fire Code (FeuVo) when planning and installing the unit.
- Contact the local chimney sweep before the end of the planning phase.
- Have the chimney sweep approve the operation of the ventilation unit.
- Correct use of a ventilation system set up with the decentralised ventilation unit requires the possibility of shutting off combustion air pipes and flue systems for solid fuel fireplaces during periods in which the fireplaces are not in use.

2.2.3 Installation in wet areas

The following rules from DIN VDE 0100-701/702 (IEC 60364-7-701) apply to installation of M-WRG-II ventilation units in wet areas:

- Protection zone 0: The unit must NOT be installed in this area.
- Protection zone 1: The unit must only be installed with the “integrated into wall” U² variant. The extract and supply air valves must be installed in the top part of the wall or in the ceiling.
- Protection zone 2 and other zone: The unit may be installed in this area.

Country-specific standards/regulations on observing the protection zones for installation in rooms with bathtub or shower must also be followed.

2.2.4 Condensate drain

The heat recovery process in our ventilation units causes condensation. This condensation is dissipated via the exhaust air pipe.

- If M-WRG-II P ventilation units are used, a condensate connection should be provided (see section 8.15 on page 33).
- With M-WRG-II E ventilation units (with enthalpy heat exchanger) there is no condensation if the following requirements are fulfilled:
 - The ventilation unit is operated as described in “Intended use” (see section 2.5 on page 10) and the “Rules for correct usage” chapter of the operating instructions.
 - There is no exceptional loading due to very high atmospheric humidity.

2.2.5 Starting and using the ventilation unit

- Do not start up the ventilation unit until it is fully installed.
- Always make sure that the cover is closed and locked in place before using the ventilation unit.
- Please note that the ventilation unit must not be used without the outer wall terminal for safety reasons.

2.3 Notes on using the ventilation units

- This unit may be used by children from 8 years old and by persons of restricted physical, sensory or mental abilities or persons lacking experience and knowledge if they are supervised or have been instructed in how to use the unit safely and understand the associated hazards. Do not allow children to play with the unit. Cleaning and user maintenance must not be carried out by children unless they are supervised.
 - ▶ Follow the regulations applicable in your country concerning the age from which people may be permitted to operate the ventilation unit.

- The ventilation unit must always be freely accessible for operation and maintenance.
 - ▶ Make sure that the ventilation unit is not covered or obstructed when the room is subsequently decorated and furnished, otherwise it cannot be operated and it will not be possible to replace the air filters. You should therefore maintain a clearance of at least 15 cm in front of the ventilation unit cover.
 - ▶ Make sure that the supply and extract air openings are not covered when the room is subsequently decorated and furnished, otherwise the ventilation unit's functions may be impaired.

2.4 Note on use in conjunction with room air conditioners

Condensation may form in the ventilation unit if the outdoor air temperature and humidity are high, but the room temperature is cool.

For these conditions, we recommend using the M-WRG-II E ventilation unit with enthalpy heat exchanger. This has the advantage of removing both sensible and latent heat from the supply air. As a result, the air is dehumidified as well as being pre-cooled. The room air conditioner needs to do less work, so the user saves money on the reduced power consumption.

2.5 Intended use

- The ventilation unit is designed to ventilate living spaces and rooms used for quasi-residential purposes. The ventilation unit is installed in a perpendicular position in the external wall. Any different or more extensive usage will be regarded as contrary to the intended use.
- The intended use also includes compliance with all the notes in the operating instructions.
- The ventilation unit must not be operated without air filters or outer wall terminal.
- The ventilation unit is intended for use in rooms with normal room air humidity levels of approx. 40 % to 70 % RH. It must not be installed in rooms in which the relative humidity during operation constantly exceeds 80 %.
- The ventilation unit's functions may be impaired or the unit may be damaged in rooms with a lot of dust (e.g. model-making) or corrosive gas emissions (e.g. blueprint shop, cleaning).
- For any use contrary to the intended use, Meltem Wärmerückgewinnung GmbH & Co. KG shall accept no liability for any damage that may occur and offers no warranty that the ventilation unit will work perfectly and correctly.

3 Planning notes

3.1 Positioning the ventilation unit indoors

The ventilation unit must be installed indoors in a perpendicular position on an external wall.

- The flush-mount installation kit (wall box) must be installed so that the openings for the flexible pipe / flat ductwork connections always point up (see Fig. 4).
- The flat ductwork system offers considerable freedom when positioning the extract air and supply air openings and the installation kit. The openings may be made directly on the installation kit or offset horizontally (item 1 in Fig. 4) or vertically (item 2 in Fig. 4). This allows the installation kit to be positioned exactly as required (item 3 in Fig. 4).

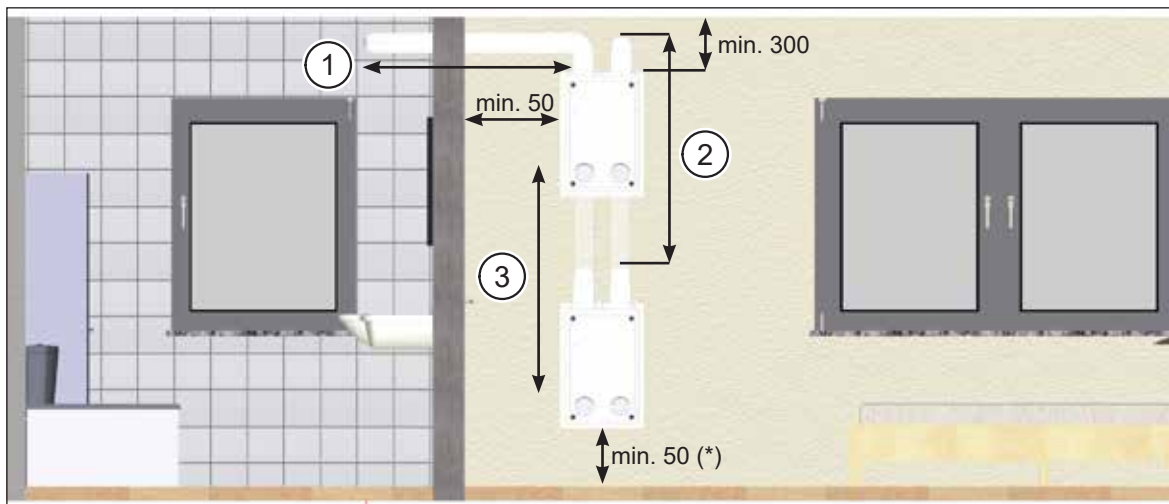

Fig. 4: Minimum distances and options for positioning the M-WRG-II M-U² installation kit, dimensions in millimetres

(*) If a condensate connection (see section 8.15 on page 33) is used, the minimum dimensions must be adapted to suit the local conditions. This applies, in particular, if condensate is drained inwards, e.g. via a greywater outlet.

- The best effect for air exchange is achieved if the supply and extract air openings are as high up the wall as possible or in the ceiling.
 - ▶ Maintain the following minimum distances (see Fig. 4 and Fig. 5):
 - For this installation kit, the distance between the top edge of the wall box and the ceiling must be at least 300 mm, otherwise there will not be enough space for connecting flat ductwork or flexible pipes.
 - The distance between the side and bottom edges of the wall box and adjacent surfaces should be at least 50 mm (exception: if a condensate connection is used, see (*) in Fig. 4). The ventilation unit will be easier to operate if this minimum distance is maintained. It also allows the air filter to be replaced without obstruction.
 - Position the supply air and extract air openings so as to avoid a short circuit between the two airflows. For example, only louvred grilles should be used in the openings in the arrangement of extract air and supply air openings shown in Fig. 12 on page 22.

- The lateral distance between two wall boxes must not be less than 200 mm to prevent an air short circuit between the ventilation units.

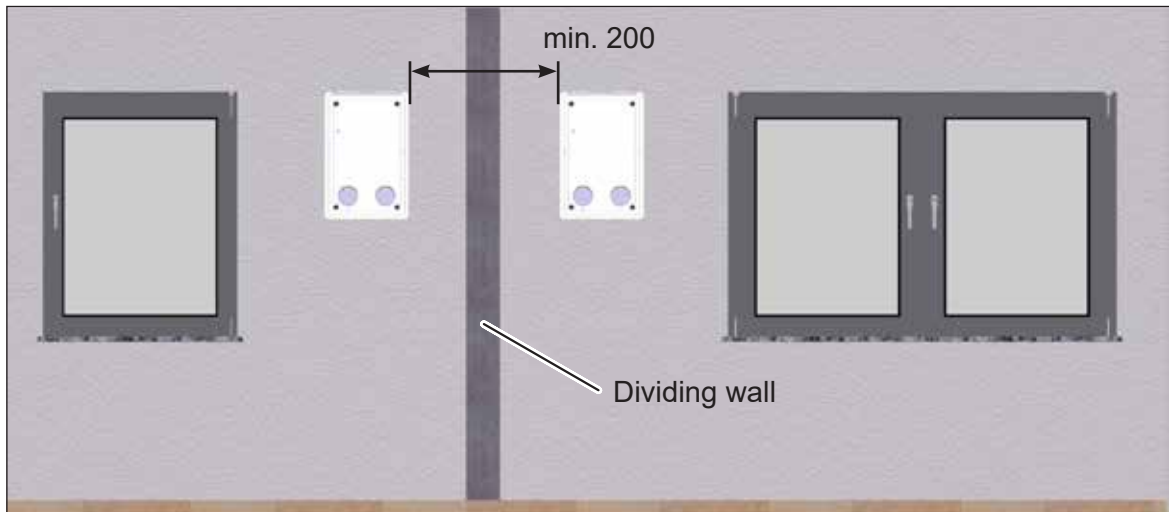

Fig. 5: Lateral minimum distance between two wall boxes, dimensions in millimetres

NOTICE

Follow the notes in Table 2 on page 26 when planning the unit. This contains information about the types of mains and control cable for each ventilation unit and the recommended operating options.

3.2 Unrestricted access to the ventilation unit

The ventilation unit must always be freely accessible for operation and maintenance.

- ▶ Make sure that the ventilation unit is not covered or obstructed when the room is subsequently decorated and furnished, otherwise it cannot be operated and it will not be possible to replace the air filters. You should therefore maintain a clearance of at least 15 cm in front of the ventilation unit cover.
- ▶ Make sure that the supply and extract air openings are not covered when the room is subsequently decorated and furnished, otherwise the ventilation unit's functions may be impaired.

3.3 Additional planning notes for this installation kit

3.3.1 Fire safety and soundproofing

⚠ WARNING

Observe the relevant fire safety and soundproofing regulations

- ▶ Observe the regulations concerning the fire behaviour of building materials and components as defined in DIN 4102 (EN 13501).
- ▶ Observe the regulations concerning soundproofing in buildings as defined in DIN 4109, particularly the requirements for insulation against airborne and impact sound.
- ▶ Observe the building regulations applicable in your country.

3.3.2 Flat ductwork

NOTICE

- ▶ Observe the following recommendations when using flat ductwork to avoid unnecessary pressure losses in the ducts.
 - Make sure that the wall aperture does not affect the local static loading and thermal insulation requirements.
 - Horizontal runs in the external wall should be as short as possible.
 - The total length of a flat duct should not exceed 6 m, as permitted by the static calculations.
 - Minimise the number of bends in the flat ductwork.

3.3.3 Flexible pipes

NOTICE

- ▶ Observe the following recommendations when using flexible pipes to avoid unnecessary pressure losses in the pipes.
 - Always connect two flexible pipes to the flexible pipe connection.
 - As far as possible, use flexible pipes with a diameter of 75 mm.
 - The total length of each flexible pipe should not exceed 10 m.
 - Minimise the number of bends in the flexible pipes.
 - Run the two flexible pipes of a flexible pipe connection in parallel to one another. The minimum distance between the flexible pipes must not be less than 3 x the pipe diameter.

3.4 Retrospectively flush-mounting the installation kit

WARNING

Danger from emerging gas or electric shock

- ▶ Make sure that there are no supply lines in the vicinity of the wall breakthrough (e.g. power, gas or water).
- ▶ Make sure that the wall breakthrough does not affect the local static loading requirements.
- ▶ Fit a lintel if necessary.
- ▶ If you are installing the kit retrospectively, run the flexible pipes in a suspended ceiling.

3.5 Electrical connection

The working voltage range of the ventilation unit is between 85 V AC and 265 V AC / 50 - 60 Hz.

NOTICE

If the ventilation unit is not equipped with a mains connection cable and plug or other means of disconnecting from the mains supply that has, at each pole, a contact opening width that conforms to the conditions of overvoltage category III for complete separation, then such an isolating unit (e.g. circuit breaker) must be integrated into the permanently installed electrical system in accordance with the installation regulations. The isolating unit must be identified as such and easy to access.

3.6 Special notes for installation in solid walls

The installation kit can be installed in solid walls that are at least 30 cm thick (including internal plaster, external render and insulation).

- ▶ For wall structures that are 70 cm thick or more, you will need 100 cm long outdoor and exhaust air pipes (M-WRG-LR 100, part no. 5580).

NOTICE

The installation kit fixes the ventilation pipes with a 2° fall to the external wall.

- The installation kit can be shortened by up to 165 mm (to no less than 273 mm). If the unplastered wall is thin (30 cm or less), do not cut off the installation kit flush with the unplastered wall (see section 8.16 on page 34). Allow the kit to protrude into the external thermal insulation composite system (ETICS) as this is the only way to allow the ventilation pipes to pass far enough through and so be fixed in place.
- When fitting the ETICS, make sure that the ventilation pipes maintain their 2° fall.

3.7 Special notes for installation in frame constructions

The installation kit can be installed in frame constructions with walls that are at least 30 cm thick (including internal plaster, external render and insulation).

- ▶ For wall structures that are 70 cm thick or more, you will need 100 cm long outdoor and exhaust air pipes (M-WRG-LR 100, part no. 5580).

NOTICE

The installation kit fixes the ventilation pipes with a 2° fall to the external wall.

- The installation kit can be shortened by up to 165 mm (to no less than 273 mm). Allow the kit to protrude into the external thermal insulation composite system (ETICS) as this is the only way to allow the ventilation pipes to pass far enough through and so be fixed in place.
- When fitting the ETICS, make sure that the ventilation pipes maintain their 2° fall.

3.7.1 Planning example for installing the installation kit in a frame construction with a framing member thickness of 160 mm

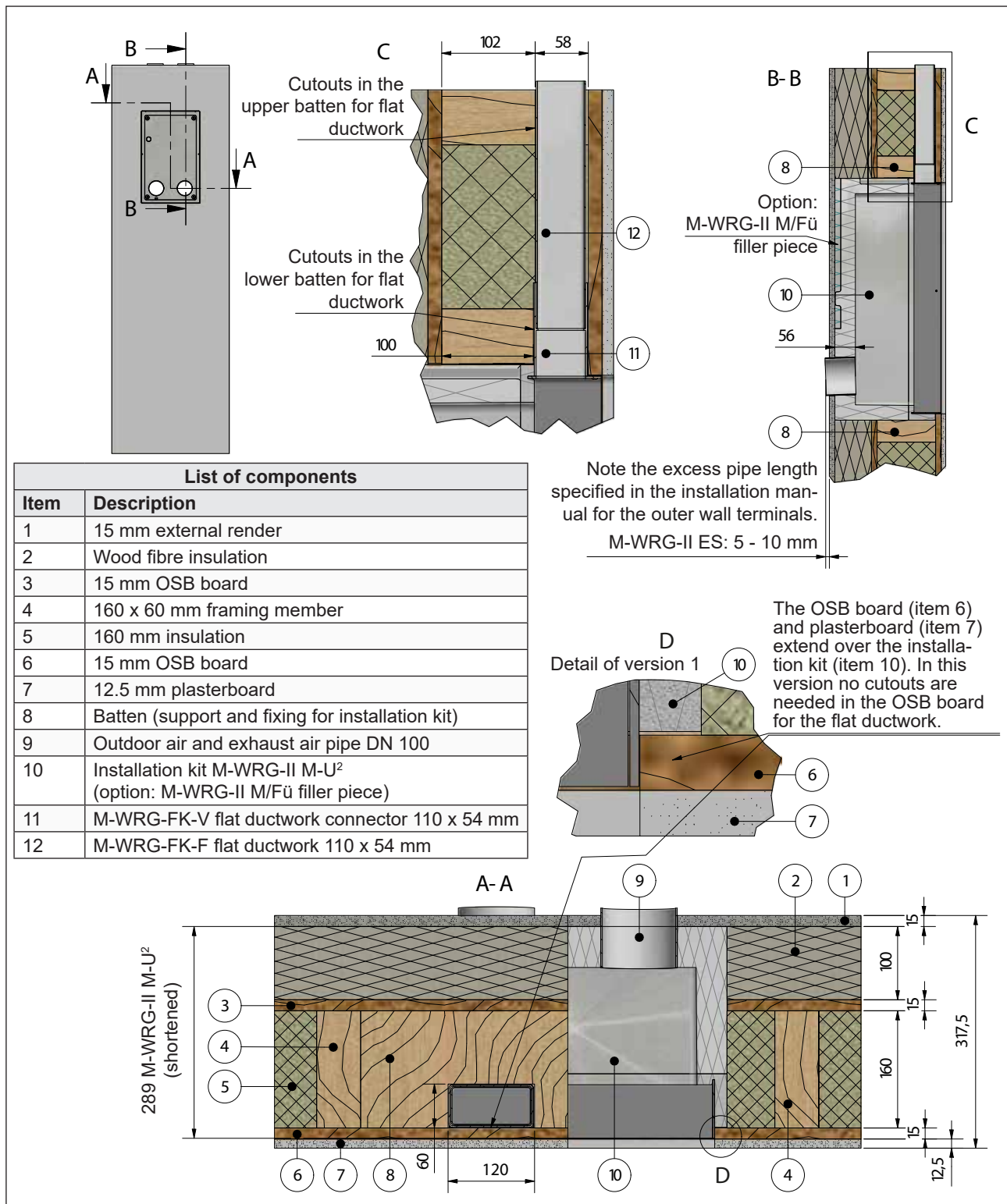

Fig. 6: Planning example for installing the installation kit in a frame construction with a framing member thickness of 160 mm

NOTICE

Frame constructions are implemented in many different ways, so it is not possible to provide a generally-applicable description for every variant. This planning example shows the installation in a frame construction with 160 mm thick framing members. The installation will have to be adapted accordingly for other framing member thicknesses or wall structures.

- ▶ If you are in any doubt, please send us a dimension drawing of your wall section so we can provide you with a custom solution.

4 Warranty and liability

4.1 Warranty

The following cases shall invalidate the warranty:

- The installation kit was not installed as described in the installation manual.
- The ventilation unit was not installed as described in the installation manual.
- The ventilation unit was flush-mounted without using a flush-mount installation kit.
- Genuine parts/genuine air filters were not replaced with genuine parts.
- Unapproved changes were made to the installation kit or ventilation unit.
- Repairs were not carried out by Meltem or by an authorised specialist company.
- The ventilation unit was operated without air filters and outer wall terminals.
- The warranty does not cover wearing parts such as air filters.

4.2 Liability

The manufacturer's liability shall not apply in the following cases:

- The installation kit was not installed as described in the installation manual.
- The ventilation unit was not installed as described in the installation manual.
- The ventilation unit was flush-mounted without using a flush-mount installation kit.
- Genuine parts/genuine air filters were not replaced with genuine parts.
- Unapproved changes were made to the installation kit or ventilation unit.
- Repairs were not carried out by Meltem or by an authorised specialist company.
- The ventilation unit was operated without air filters and outer wall terminals.

5 Items supplied

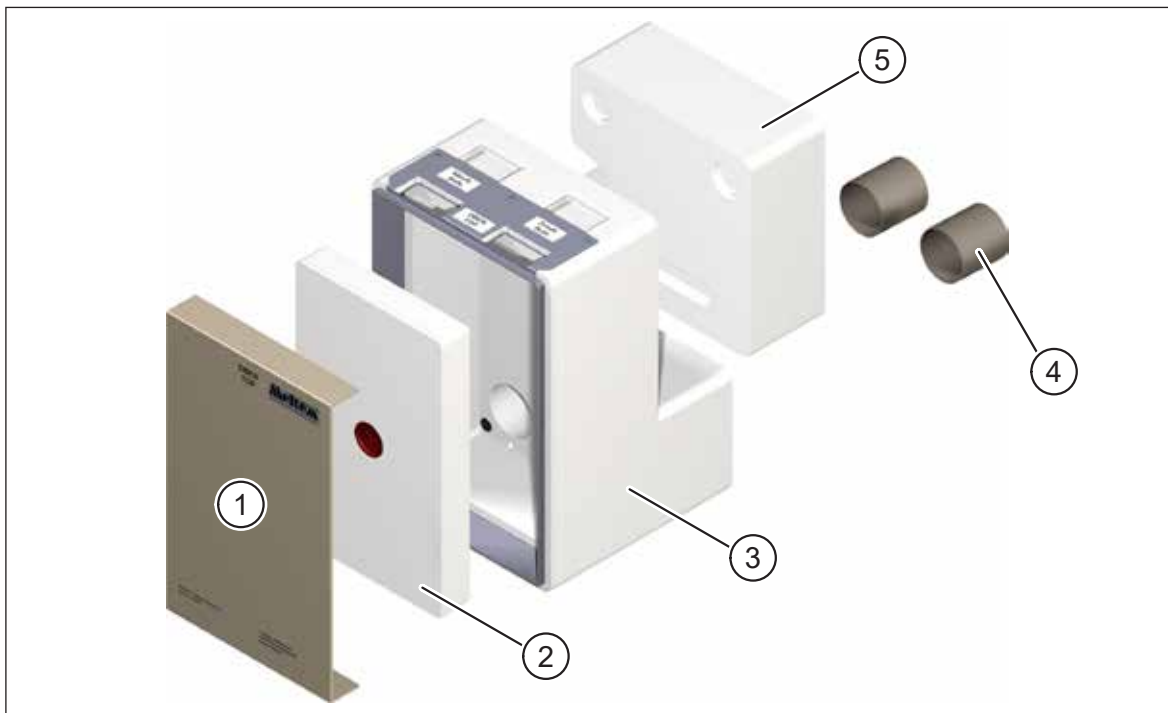

Fig. 7: Items supplied with the installation kit M-WRG-II M-U²

5.1 M-WRG-II M-U² installation kit, part no. 712000

Item	Description	Quantity
1	Plaster cover for wall box	1 x
2	Protective cover	1 x
3	Wall box	1 x
4	Protective sleeve	2 x

5.2 Options

Item	Description	Part no.
5	Installation kit filler piece M-WRG-II M/Fü	735003
-	Plaster scrim M-WRG-II PG	735000

5.3 Installation materials required

Additional installation materials are needed for flush-mount installation. These must be ordered separately.

Item	Description	Part no.
-	Outdoor air and exhaust air pipe, DN 100, 2 x 0.5 m, M-WRG-LR 50	5574
-	If a condensate connection is used: Outdoor air and exhaust air pipes, DN 100, 2 x 0.5 m, exhaust air pipe with 1/2" male thread condensate connection, M-WRG-II LR 50-KA	735200

6 Dimensions of the installation kit

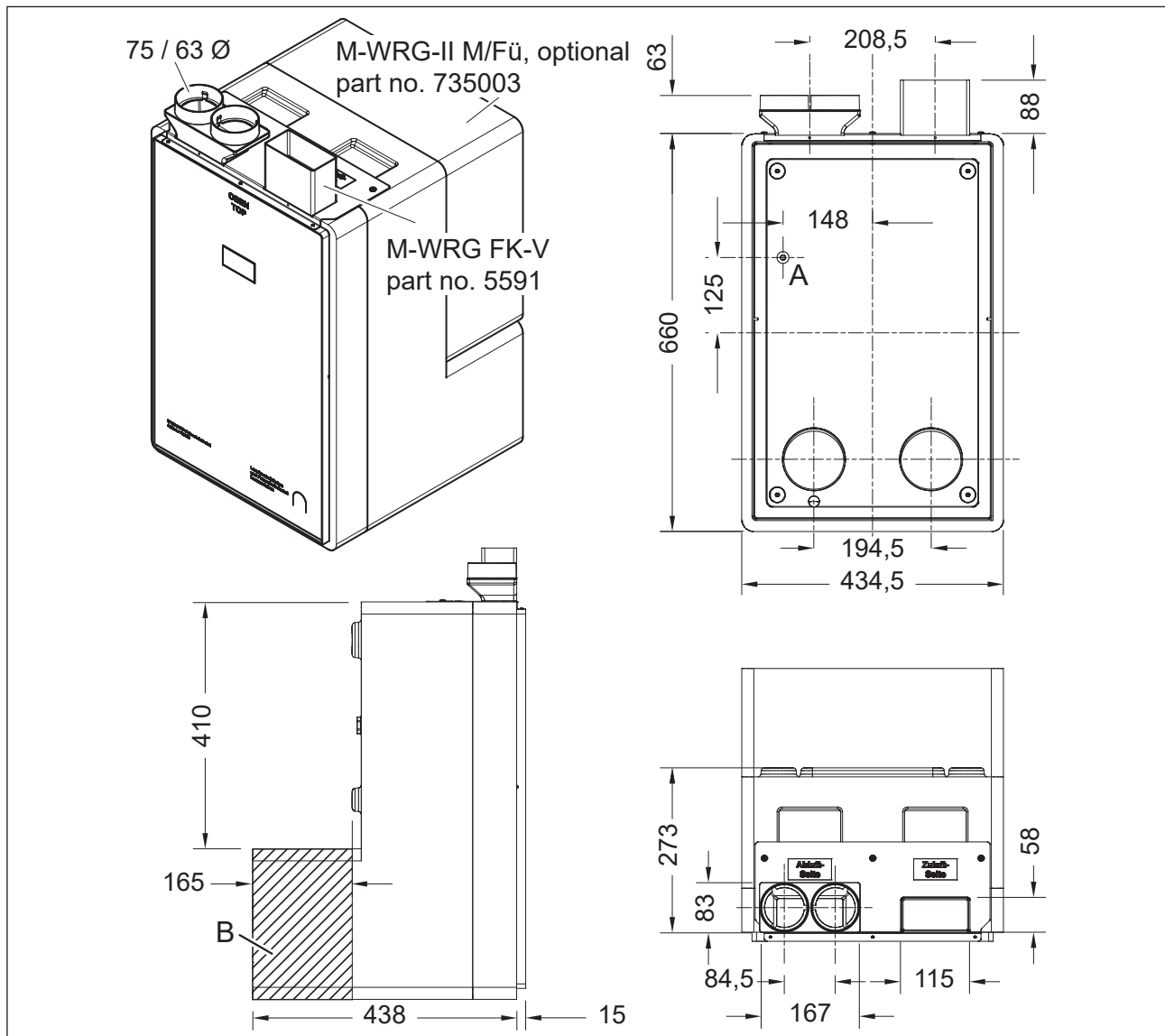

Fig. 8: Dimensions of the installation kit with optional filler piece in millimetres

- A Cable inlet for the mains and control cables (a control cable is only needed for certain ventilation units, see Table 2 on page 26)
- B The installation kit can be shortened by up to 165 mm (to no less than 273 mm). Two flat ductwork connections **or** two flexible pipe connections **or** one flat ductwork connection and one flexible pipe connection may be used in the extract air and supply air openings. A configuration with flat ductwork (FK) and flexible pipe connection (diameter of 75 / 63 mm) was used in Fig. 8 to illustrate the dimensioning of the flat ductwork and flexible pipe connections.

NOTICE

With the M-WRG-II WM-M-U² option, part no. 720005, the kit can be shortened at the factory to a minimum length of 258 mm.

7 General installation instructions

The M-WRG-II M-U² installation kit is suitable for installation in solid walls and frame constructions:

- **Installation of the installation kit in solid walls** is described in section “8 Installing the installation kit in a solid wall” from page 19.
- **Installation of the installation kit in frame constructions** is described in section “9 Installing the installation kit in a frame construction” from page 39.

NOTICE

- The installation must be carried out in accordance with the generally acknowledged rules of technology.
- Connections with adjacent components must be formed to absorb movements between the contact surfaces.
- Seal any connections that are exposed to driving rain with tapes, profiles or sealants such that they offer sufficient protection against the expected conditions.

⚠ WARNING

Follow the relevant accident prevention regulations

- ▶ Follow the accident prevention regulations when setting up the installation location.
- ▶ Protect the outside area against falling parts.

8 Installing the installation kit in a solid wall

8.1 Tools and equipment required

- Permanently elastic sealant, solvent-free if applied to polystyrene
- Sealing tape, 30 mm wide, e.g. Coroplast
- Wedges for fixing the wall box, 8 x; if necessary, wedges for fixing the filler piece, 4 x alternatively use inflatable air cushions, e.g. Amo-Bag from Würth, part no. 07156780
- Adhesive tape
- Wall chaser
- Expanding foam with abP (national technical test certificate of the DIBt) approval (“exact gap” foam is recommended)
- Saw for cutting the ventilation pipes to length
- Styrofoam saw
- Spirit level
- Optionally if the ductwork is riveted to the installation kit:
 - Riveter and blind rivets $\varnothing 3 \times 6$ mm
 - Cordless screwdriver with 3 mm drill bit

NOTICE

If the installation kit is to be retrospectively installed in a solid wall, you will need additional tools to break through the wall.

8.2 Breaking through the wall

The wall breakthrough can either be included when planning a new build or subsequently made in the solid wall.

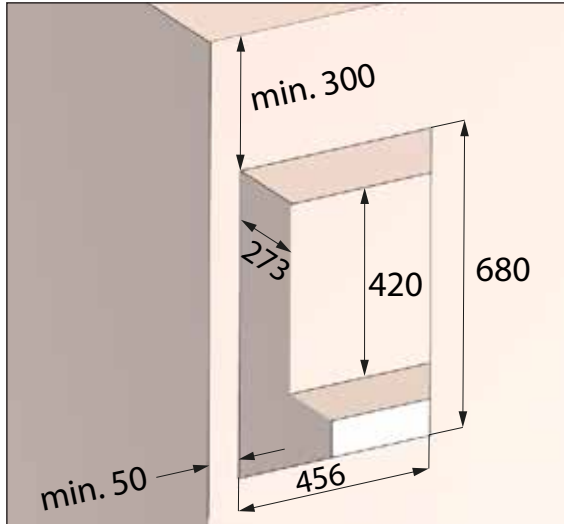

Fig. 9: Wall breakthrough for installation kit **without** filler piece, dimensions in millimetres

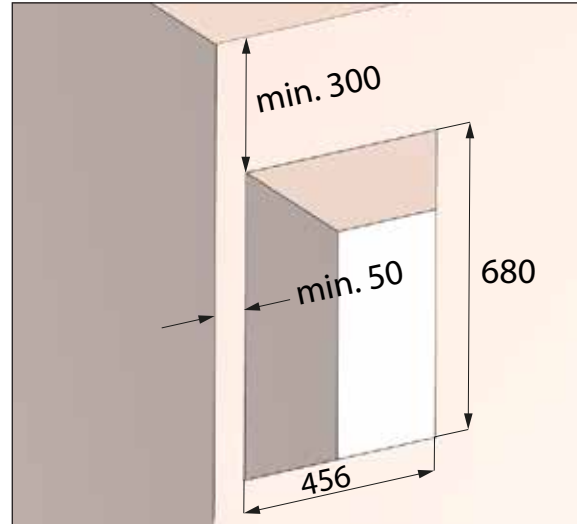

Fig. 10: Wall breakthrough for installation kit **with** filler piece, dimensions in millimetres

8.2.1 Planning the wall breakthrough for new builds

- ▶ Commission an architect or design professional to include the wall breakthrough at a suitable point in the construction drawing and execute it when constructing the building shell.

There are two possible versions of the wall breakthrough:

- Wall breakthrough with recess (see Fig. 9) for installation kit **without** filler piece M-WRG-II M/Fü
- Complete wall breakthrough (see Fig. 10) for installation kit **with** filler piece M-WRG-II M/Fü

8.2.2 Breaking through an existing wall

⚠ WARNING

Danger due to damaging supply lines and changing the stress loadings

- ▶ Make sure that there are no supply lines in the vicinity of the wall breakthrough (e.g. power, gas or water).
- ▶ Make sure that the wall breakthrough does not affect the local static loading requirements.
- ▶ Fit a lintel if necessary.

- ▶ Break through the wall. There are two possible versions of the wall breakthrough:
 - Wall breakthrough with recess (see Fig. 9 on page 20) for installation kit **without** filler piece M-WRG-II M/Fü
 - Complete wall breakthrough (see Fig. 10 on page 20) for installation kit **with** filler piece M-WRG-II M/Fü

8.3 Chasing out channels for flat ductwork or flexible pipes

NOTICE

With this installation kit you can connect to the extract air and supply air openings using either flat ductwork or flexible pipe. Various sample configurations are illustrated below.

8.3.1 Chasing out channels for two flat ductwork connections (single room version)

- ▶ Use the wall chaser to chase out two channels 125 mm wide, 70 mm deep and at least 210 mm high (see Fig. 11) for both the extract air duct (item 1 in Fig. 11) and the supply air duct (item 2 in Fig. 11).
- ▶ Check that the installation kit fits easily into the wall breakthrough.
- ▶ Check that the installation kit can be pushed far enough into the wall breakthrough for the front surface to end flush against the solid wall; the plastering trim must protrude 15 mm beyond the solid wall.
- ▶ If necessary, use the wall chaser to chase out channels for the rest of the flat ductwork as shown in your plans.

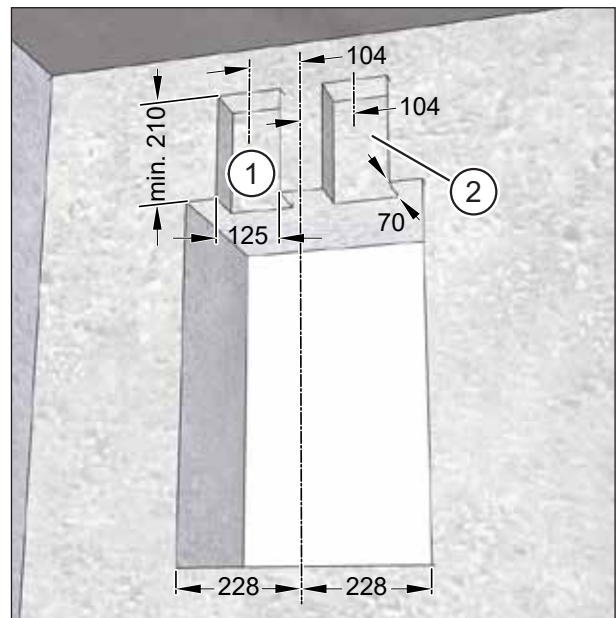

Fig. 11: Chasing out channels for flat ductwork connections, dimensions in millimetres

Fig. 12 and Fig. 13 on page 22 show examples with the flat ductwork running vertically and horizontally.

NOTICE

The dimensions of the wall channels for the flat ducts are:

- 125 mm wide
- 70 mm deep

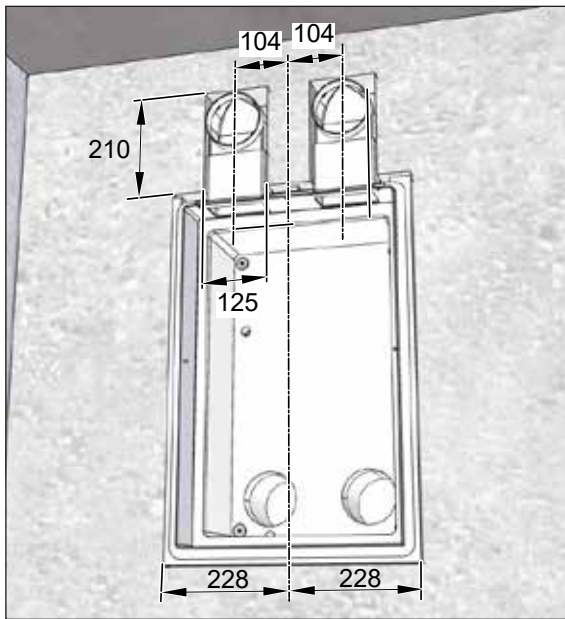

Fig. 12: Vertical flat ductwork layout example, dimensions in millimetres

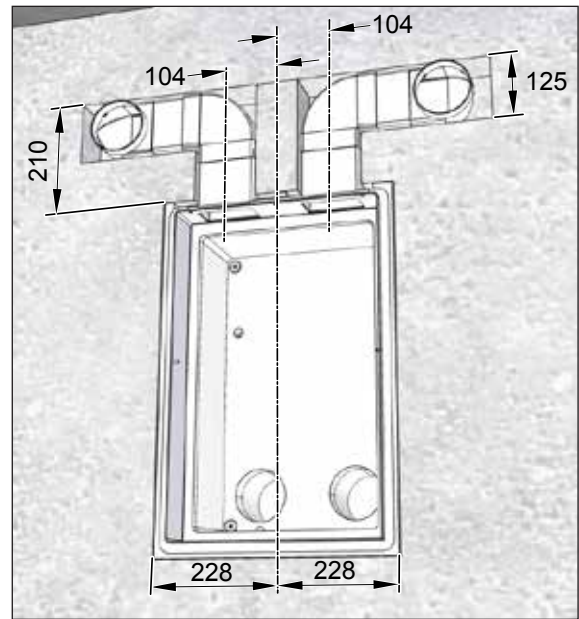

Fig. 13: Horizontal flat ductwork layout example, dimensions in millimetres

NOTICE

In the arrangement of extract air and supply air openings shown in Fig. 12, **only use louvred grilles** in the openings. The louvres should point towards the ceiling to avoid an air short circuit.

8.3.2 Chasing out channels for connecting flat ductwork (multi-room version)

- ▶ Use the wall chaser to chase out two channels 125 mm wide, 70 mm deep and at least 210 mm high (see Fig. 14) for both the extract air duct (item 1 in Fig. 14) and the supply air duct (item 2 in Fig. 14).
- ▶ Check that the installation kit fits easily into the wall breakthrough.
- ▶ Check that the installation kit can be pushed far enough into the wall breakthrough for the front surface to end flush against the solid wall; the plastering trim must protrude 15 mm beyond the solid wall.
- ▶ If necessary, use the wall chaser to chase out channels for the rest of the flat ductwork as shown in your plans.

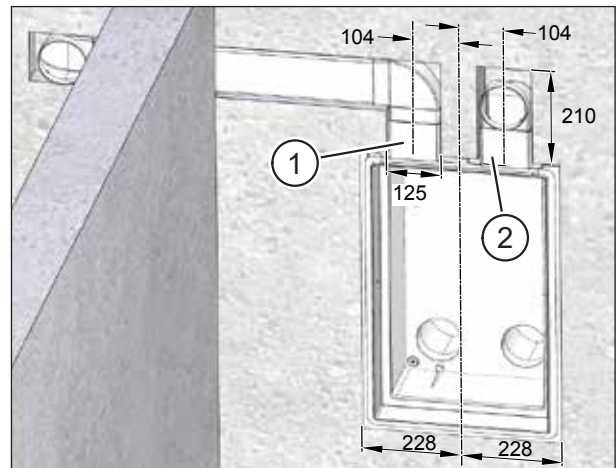

Fig. 14: Chasing out channels for ductwork connection with flat ductwork, dimensions in millimetres

Fig. 14 shows an example with the flat ductwork running vertically and horizontally.

NOTICE

The dimensions of the wall channels for the flat ducts are:

- 125 mm wide
- 70 mm deep

8.3.3 Chasing out channels for connecting flexible pipes (multi-room version)

- ▶ Chase out the channels for the flat ductwork and flexible pipe connection according to which connections you intend to use for the extract and supply air.
 - Fig. 15: **extract air** (item 1) flat ductwork connection, **supply air** (item 2) flexible pipe connection
 - Fig. 16: **extract air** (item 1) flexible pipe connection, **supply air** (item 2) flat ductwork connection
- ▶ Use the wall chaser to chase out a channel for the flat ductwork as described in section “8.3.1 Chasing out channels for two flat ductwork connections (single room version)” on page 21.
- ▶ Use the wall chaser to chase out one channel for the flexible pipe 190 mm wide and 90 mm deep as far as the flexible pipe outlet in the ceiling (see Fig. 15 and Fig. 16 on page 23).
- ▶ Check that the installation kit fits easily into the wall breakthrough.
- ▶ Check that the installation kit can be pushed far enough into the wall breakthrough for the front surface to end flush against the solid wall; the plastering trim must protrude 15 mm beyond the solid wall.

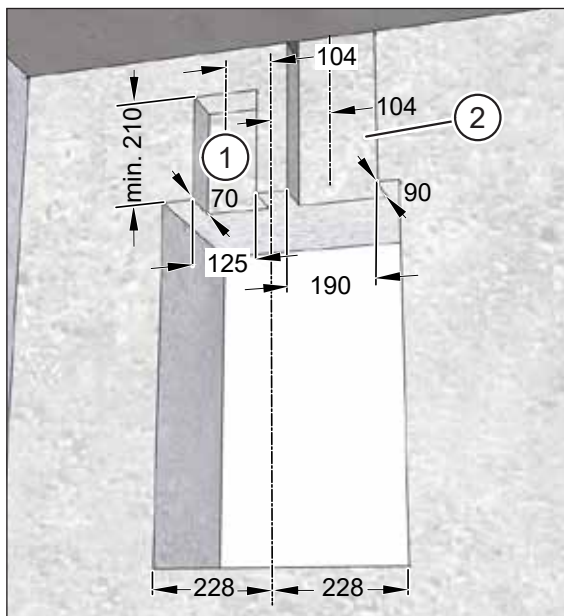

Fig. 15: Chasing out channels for flat ductwork and flexible pipe connections, dimensions in millimetres

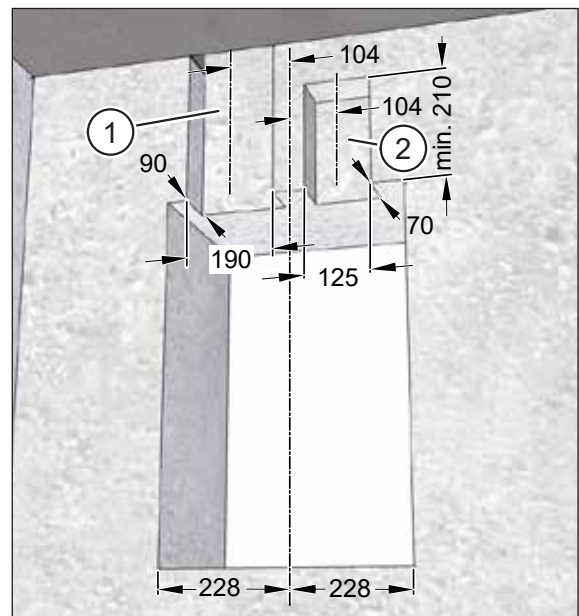

Fig. 16: Chasing out channels for flexible pipe and flat ductwork connections, dimensions in millimetres

NOTICE

- ▶ Observe the following recommendations when using flexible pipes to avoid unnecessary pressure losses in the pipes.
 - Always connect two flexible pipes to the flexible pipe connection.
 - As far as possible, use flexible pipes with a diameter of 75 mm.
 - The total length of each flexible pipe should not exceed 10 m.
 - Minimise the number of bends in the flexible pipes.
 - Run the two flexible pipes of a flexible pipe connection in parallel to one another. The minimum distance between the flexible pipes must not be less than 3 x the pipe diameter.

Fig. 17 contains a planning example for running a flat duct and the flexible pipes. Always run 2 flexible pipes in the supply air or extract air room.

NOTICE

The dimensions of the wall channels for the flat ducts are:

- 125 mm wide
- 70 mm deep

The dimensions of the wall channels for the flexible pipes are:

- 190 mm wide
- 90 mm deep

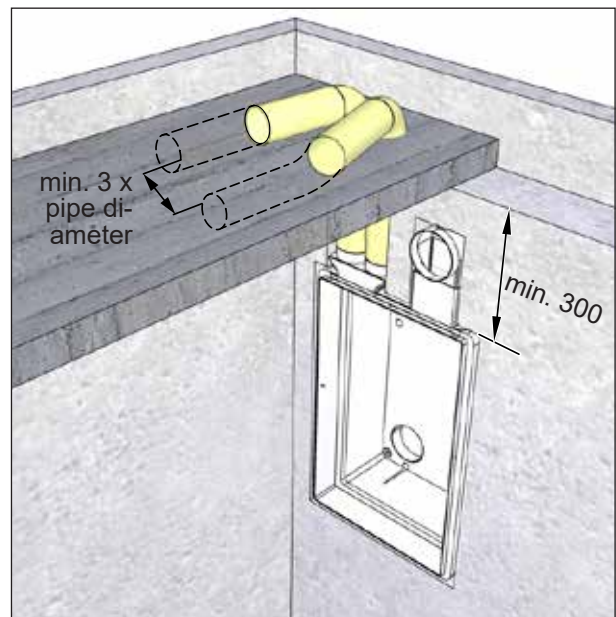

Fig. 17: Planning example for running flat ductwork and flexible pipes

8.4 Chasing out channels for connecting cables

- ▶ Chase out a channel for the mains and control cables (item 1 in Fig. 18).

NOTICE

The wall channel in Fig. 18 is shown by way of example. An alternative wall channel is shown as dashed lines (item 2 in Fig. 18). For the subsequent electrical installation work, we recommend running the mains and control cables from the left at the wall breakthrough.

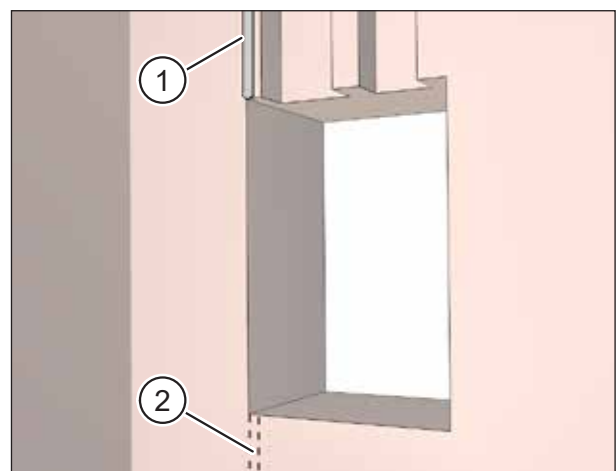

Fig. 18: Chasing out channels for connecting cables

8.5 Running the mains and control cables

⚠ DANGER

Potentially fatal voltages

- The electrical installation work must only be carried out by a qualified electrician.
- The VDE regulations or any special safety regulations applicable in your country apply to the electrical installation work.
- ▶ Before starting installation or maintenance work, disconnect the mains cable for connecting to the ventilation unit on all poles from the mains supply.
- ▶ Observe the five safety rules (DIN VDE 0105-100, EN 50110-1) for working on electrical systems:
 - Disconnect from mains (all-pole disconnection of a system from live parts)
 - Secure against reconnection
 - Check that the system is voltage-free
 - Earth and short-circuit
 - Cover or block off access to adjacent live parts

- ▶ Run the mains cable (item 1 in Fig. 19) and the control cable, if required (item 2 in Fig. 19). The cables should extend roughly 250 mm beyond the wall.
- ▶ Fix the mains cable and the control cable (if used) in position.

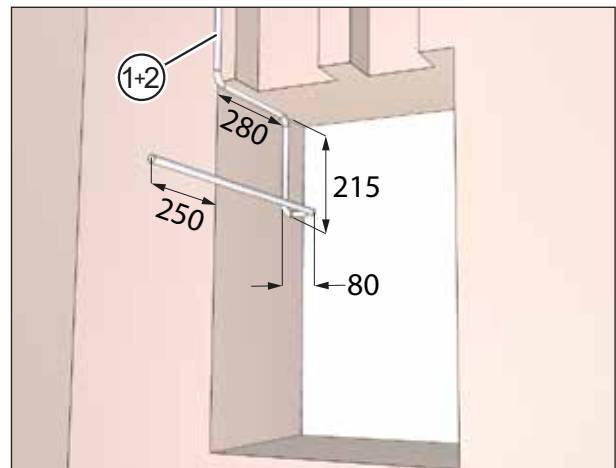

Fig. 19: Running the connecting cables, dimensions in millimetres

NOTICE

- Table 2 on page 26 and Table 3 on page 27 contain overviews of the recommended types of mains cable and control cable.
- A control cable is only needed for certain types of ventilation unit.
- The ventilation unit is equipped with an external control input as standard. The mains cable **NYM-J 4x1.5 mm²** is needed if this control input is used.

8.5.1 Cable types

Part no.	Type of ventilation unit	Type of mains cable	Type of control cable
700000 (*) 700001 (*) 700002 (*) 701000 (*) 701001 (*) 701002 (*)	M-WRG-II P M-WRG-II P-F M-WRG-II P-FC M-WRG-II E M-WRG-II E-F M-WRG-II E-FC	NYM-J 3x1.5 mm ² or NYM-J 4x1.5 mm ² (**)	No control cable
700010 700011 700012 701010 701011 701012	M-WRG-II P-T M-WRG-II P-T-F M-WRG-II P-T-FC M-WRG-II E-T M-WRG-II E-T-F M-WRG-II E-T-FC	NYM-J 3x1.5 mm ² or NYM-J 4x1.5 mm ² (**)	— InControl pushbutton sensor: J-Y (St) Y 10x2x0.6 mm / J-Y (St) Y 10x2x0.8 mm — Three-step rotary switch: J-Y (St) Y 4x2x0.6 mm / J-Y (St) Y 4x2x0.8 mm — BCD encoding: J-Y (St) Y 4x2x0.6 mm / J-Y (St) Y 4x2x0.8 mm
700020 700021 700022 701020 701021 701022	M-WRG-II P-M M-WRG-II P-M-F M-WRG-II P-M-FC M-WRG-II E-M M-WRG-II E-M-F M-WRG-II E-M-FC	NYM-J 3x1.5 mm ² or NYM-J 4x1.5 mm ² (**)	Building management system, Modbus, Loxone, KNX: J-Y (St) Y 2x2x0.6 mm / J-Y (St) Y 2x2x0.8 mm
700030 700031 700032 701030 701031 701032	M-WRG-II P-S 485 M-WRG-II P-S 485-F M-WRG-II P-S 485-FC M-WRG-II E-S 485 M-WRG-II E-S 485-F M-WRG-II E-S 485-FC	NYM-J 3x1.5 mm ² or NYM-J 4x1.5 mm ² (**)	Touch Control network: J-Y (St) Y 2x2x0.6 mm / J-Y (St) Y 2x2x0.8 mm

Table 2: Types of mains cable and control cable for each ventilation unit type

(*) If you install these types of ventilation unit in the M-WRG-II M-U² installation kit, we recommend that you use the following options to operate the ventilation units:

- Using the app via the gateway M-WRG-GW, part no. 5453-00
- Wireless remote control M-WRG-FBH, part no. 5478-10
- 4-way wireless pushbutton switch M-WRG-FT, part no. 5478-20
- External wireless humidity sensor M-WRG-II FSF, part no. 733010
- External wireless CO₂ sensor M-WRG-II FSC, part no. 733011

(**) If the external control input is used

8.5.2 External control input

With the external control input supplied as standard, the M-WRG-II unit has an additional input terminal for 230 V AC (working voltage range: 85 V AC to 265 V AC / 50 - 60 Hz) to which a switch, time switch, motion detector or similar may be connected.

The external control input is equipped with a time-delay relay that can be used to set a switch-on delay and a run-on time:

- Switch-on delay: the M-WRG-II unit does not start until the set time has elapsed.
- Run-on time: the M-WRG-II unit does not switch to the previously active ventilation program until the set time has elapsed.

In addition, the following options are available for the external control input supplied as standard:

- M-WRG-II O/EST-1 (without switch-on delay, part no. 721005)
- M-WRG-II O/EST-2 (without run-on time, part no. 721006)

Windowless rooms can be ventilated in accordance with DIN 18017-3 in combination with the M-WRG-II O/NOF option (part no. 721004).

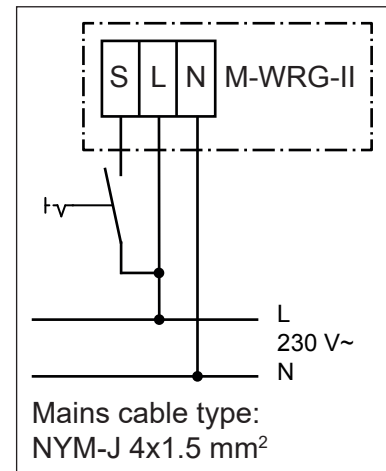

Fig. 20: Connection diagram for external control input

8.5.3 Option M-WRG-II O/EGG-AUS

Part no.	Option M-WRG-II O/EGG-AUS	Type of control cable
721003	“Unit OFF” input, e.g. via an external smoke detector or window contact	J-Y (St) Y 2x2x0.6 mm / J-Y (St) Y 2x2x0.8 mm
	Potential-free fault indicator output	J-Y (St) Y 2x2x0.6 mm / J-Y (St) Y 2x2x0.8 mm

Table 3: Option M-WRG-II O/EGG-AUS

The connection board for the M-WRG-II O/EGG-AUS option has 5 terminals (see Fig. 21):

- 3-pole connection for fault indicator output
- 2-pole connection for “Unit OFF” input

We recommend that you use separate cables for the input and output.

NOTICE

The M-WRG-II O/EGG-AUS option must be installed at the factory.

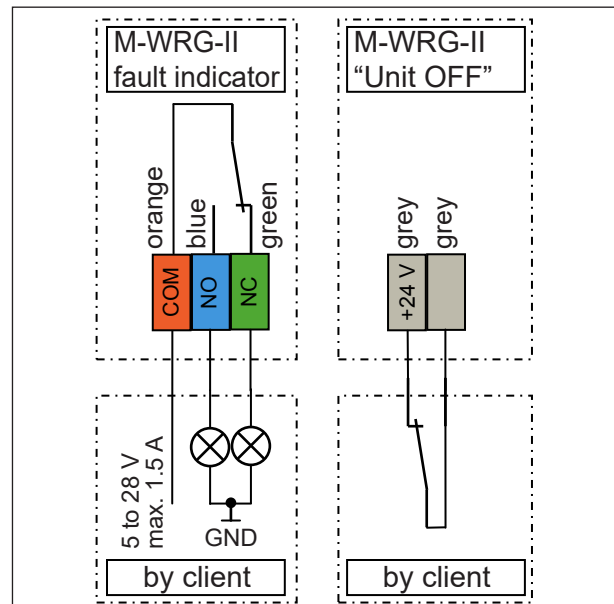

Fig. 21: Connection diagrams for M-WRG-II O/EGG-AUS option

8.6 Inserting the wall box

NOTICE

- ▶ Prepare the breakthrough surfaces suitably for the wall box.
- ▶ Remove the plaster cover (item 1 in Fig. 22) and the protective cover (item 2 in Fig. 22) from the wall box (item 3 in Fig. 22).
- ▶ Thread the mains cable and the control cable, if required (item 4 in Fig. 22), through the cable inlet in the wall box (item 5 in Fig. 22).
- ▶ Push the wall box (item 3 in Fig. 22) fully into the wall breakthrough.

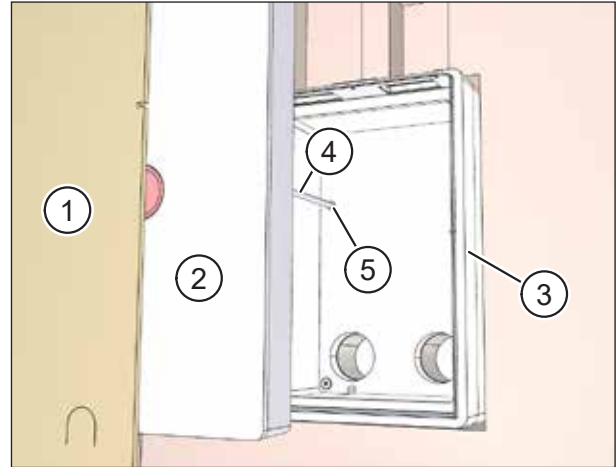

Fig. 22: Inserting the wall box

8.7 Inserting the protective cover and plaster cover

- ▶ Insert the protective cover (item 1 in Fig. 23) into the wall box (item 3 in Fig. 23).

NOTICE

When the gaps around the wall box are filled with foam (see section 8.9 on page 29), there is a risk that the wall box will be deformed by the pressure of the foam if the protective cover is not inserted. If this happens, it will not be possible to insert the ventilation unit into the wall box.

- ▶ Insert the plaster cover (item 2 in Fig. 23) into the wall box (item 3 in Fig. 23) as far as it will go.

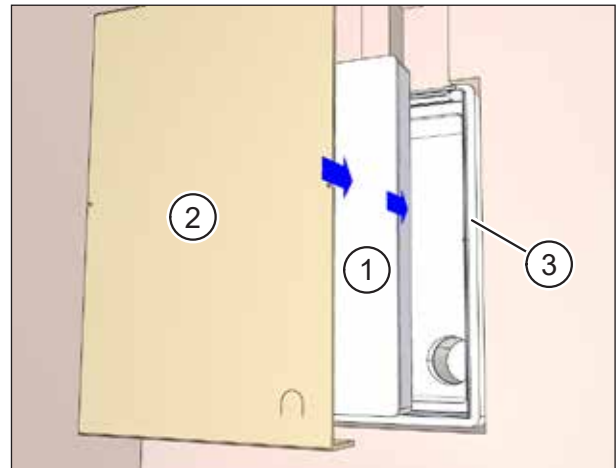

Fig. 23: Inserting the protective cover and plaster cover

8.8 Fixing the wall box

- ▶ Fix the wall box (item 1 in Fig. 24) in position in the wall breakthrough using wedges or air cushions (item 2 in Fig. 24) on both the inside and the outside.
- ▶ Use the spirit level (item 3 in Fig. 24) to align the wall box so that it is perpendicular and flush with the wall.

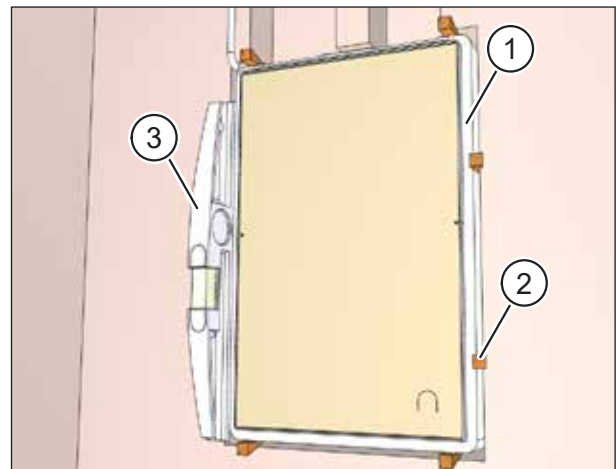

Fig. 24: Fixing the wall box

NOTICE

- ▶ Make sure that the wall box is perpendicular as this is the only way to ensure that any condensation will be carried outside by the 2° pipe fall.
- ▶ Fix the filler piece, if needed, to the external wall with wedges or air cushions.

NOTICE

The plastering trim is 15 mm deep (see Fig. 25).

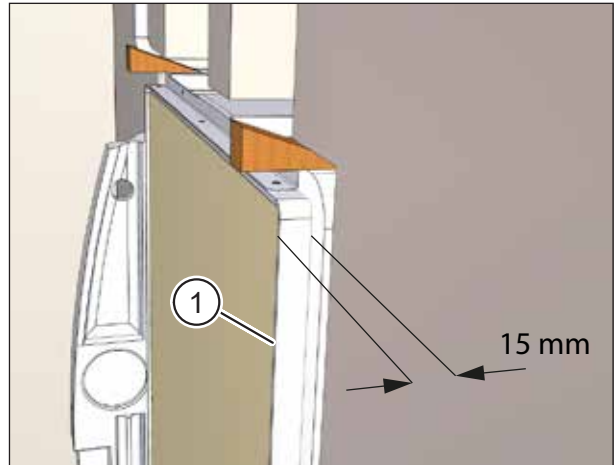

Fig. 25: Depth of plastering trim 15 mm

- ▶ If the depth of plaster should be more than 15 mm, position the wall box so that it protrudes sufficiently out of the solid wall. If you do not do this, there is a risk that the ventilation unit will not work correctly.
- ▶ If the interior wall is not perpendicular or flat, align the front surface of the plastering trim (item 1 in Fig. 25) parallel to a plaster stop bead running vertically.

8.9 Filling gaps around the wall box with foam

NOTICE

- ▶ Check that the protective cover (item 1 in Fig. 22 on page 28) is inserted before filling with foam.
- ▶ Check that the wall box is seated correctly. Once you have used the foam, you will not be able to align it further.

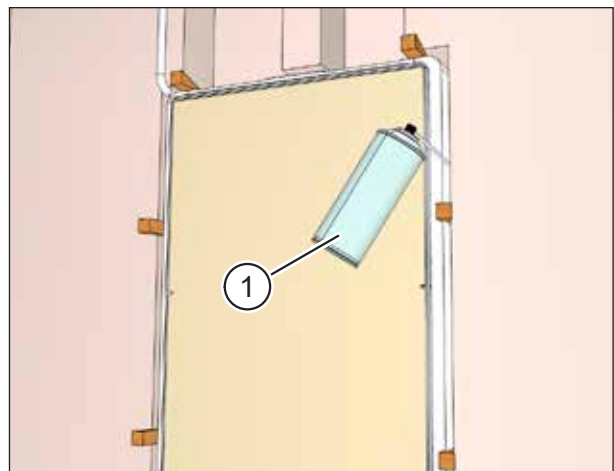

Fig. 26: Filling gaps around the wall box with foam

- ▶ Fill the gaps between the wall box and wall breakthrough all around and continuously with expanding foam (item 1 in Fig. 26) or using another suitable filling material.

Be careful not to block the extract air and supply air openings at the top of the wall box with the expanding foam.

- ▶ Once the foam has hardened, remove any wedges that extend beyond the solid wall.

8.10 Inserting flat ductwork into channels

NOTICE

If you are using flexible pipes, continue from section “8.11 Cutting flexible pipes to length” on page 30.

- ▶ Insert a fitting, e.g. the flat ductwork connector M-WRG-FK-V, part no. 5591 (item 1 in Fig. 27), into the opening in the wall box.

NOTICE

All fittings (flat ductwork connectors, bends, angles, etc.) inserted into the opening in the wall box must have the external dimensions 115 x 58 mm. Elements with the external dimensions 110 x 54 mm, e.g. flat ductwork, are designed to be inserted into the fittings. They must not be inserted directly into the opening in the wall box.

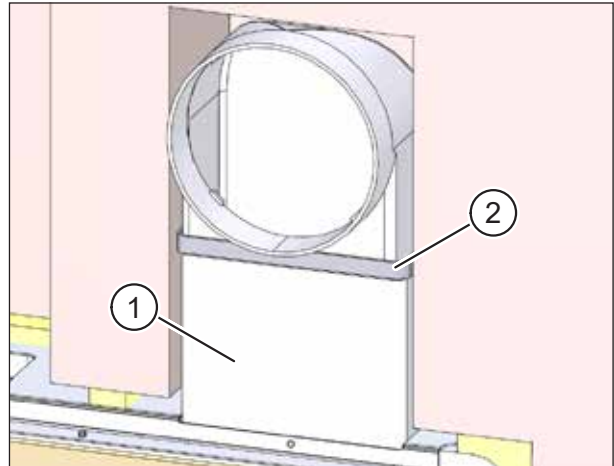

Fig. 27: Fixing ductwork connections with sealing tape

- ▶ Join individual elements of the flat ductwork to create partial sections and seal every join with a layer of sealing tape 30 mm wide.
- ▶ Insert the first section of the flat ductwork into the fitting, e.g. the flat ductwork connector M-WRG-FK-V, part no. 5591, on the wall box and seal the join with sealing tape (item 2 in Fig. 27).
- ▶ Insert the sections of flat ductwork into the wall channel one after another and seal every join with sealing tape.
- ▶ Fix the flat ductwork in place with expanding foam. This will improve both the seal and the insulation.

8.11 Cutting flexible pipes to length

- ▶ Remove the red protective cover (item 1 in Fig. 28) from the flexible pipe connection (item 3 in Fig. 28).
- ▶ Shorten the flexible pipes (item 2 in Fig. 28) so that the flexible pipe connection (item 3 in Fig. 28) with the flexible pipes inserted can be pushed into the opening on the wall box.

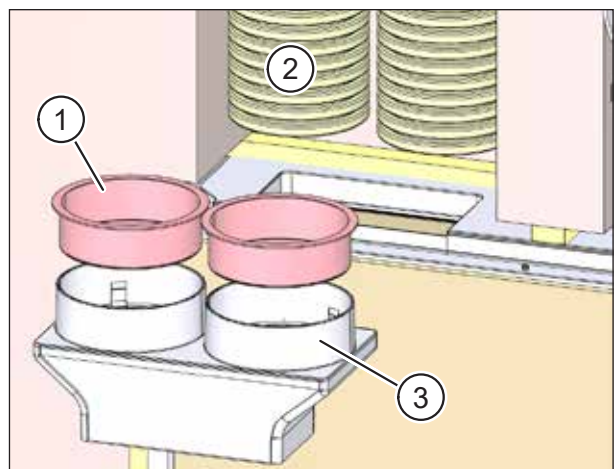

Fig. 28: Cutting flexible pipes to length

8.12 Inserting flexible pipes into the flexible pipe connection

- ▶ Insert the sealing rings (item 1 in Fig. 29) into the second groove on the flexible pipe. These are available as accessories M-WRG-FR-DR75 (part no. 5056-41/75) or M-WRG-FR-DR63 (part no. 5056-41/63) for the corresponding diameters.
- ▶ Insert the flexible pipes into the openings in the flexible pipe connection. Make sure that the first groove on the flexible pipe (item 2 in Fig. 29) engages with the locking ring (item 3 in Fig. 29) on the flexible pipe connection.
- ▶ Recommendation: Seal the join with a layer of sealing tape 30 mm wide (item 4 in Fig. 29).
- ▶ Insert the flexible pipe connection (item 5 in Fig. 29) into the opening in the wall box.

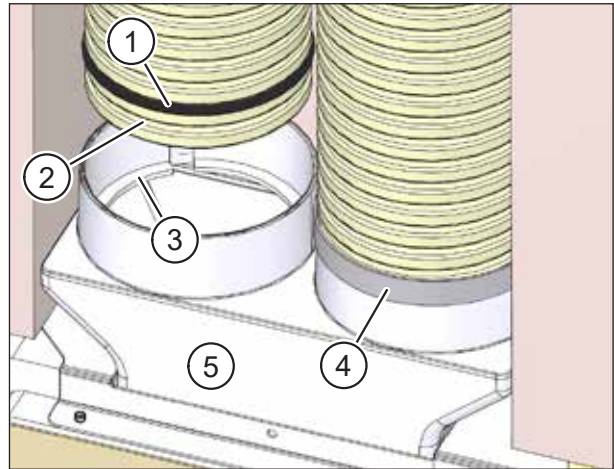

Fig. 29: Fixing a flexible pipe connection with sealing tape

NOTICE

- ▶ Run the flexible pipes without forcing or stresses.
- ▶ Fix the flexible pipes in place with expanding foam.

8.13 Fixing the connections for flat ductwork/flexible pipe to the wall box

There are two holes (item 1 in Fig. 30) in the plastering trim for fixing the flat ductwork or flexible pipe connections to the wall box with blind rivets if necessary. These holes will also need to be drilled in the flat ductwork or flexible pipe connections.

- ▶ Use the 3 mm drill bit to drill through the holes in the plastering trim (item 1 in Fig. 30) and into the flat ductwork or flexible pipe connections.
- ▶ Use the riveter to fix the flat ductwork or flexible pipe connection to the plastering trim for the wall box.

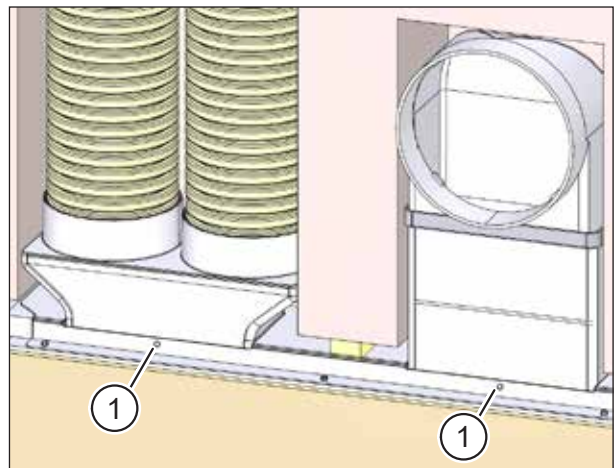

Fig. 30: Fixing the connections for flat ductwork/flexible pipe to the wall box

8.14 Plastering the installation kit and flat ductwork / flexible pipes on the inside

NOTICE

- ▶ Prepare the substrate suitably before plastering.
- ▶ Make sure that the plaster cover (item 1 in Fig. 31) is seated in the wall box.
- ▶ Cut off any excess expanding foam on the wall box and flat ductwork / flexible pipes.
- ▶ Use adhesive tape to cover over the extract air and supply air outlets (item 2 in Fig. 31).
- ▶ Apply the plaster scrim M-WRG-II PG (item 3 in Fig. 31) to the installation kit and the solid wall.
- ▶ Cover the flat ductwork with plaster scrim.
- ▶ Cover the flexible pipes with plaster scrim as far as the outlet in the ceiling.

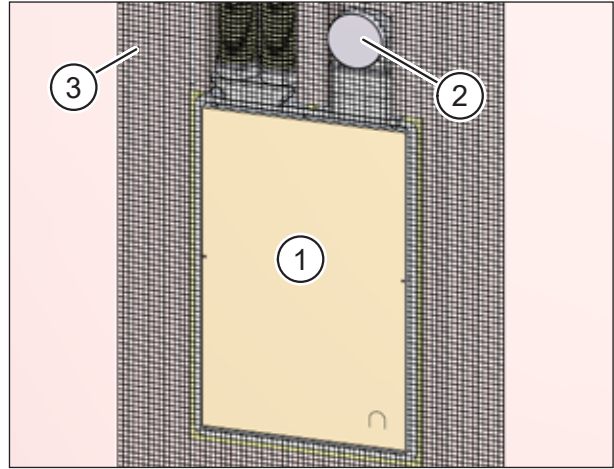

Fig. 31: Plastering the installation kit and flat ductwork / flexible pipes on the inside

NOTICE

Applying plaster scrim will minimise subsequent cracking of the plaster.

- ▶ Plaster the internal wall. The plaster forms the airtight layer on the internal wall. The expanding foam does not act as an airtight layer.
- ▶ When plastering, make sure that the plaster ends flush with the plastering trim. The following situations are not permitted:
 - The plastering trim (item 1 in Fig. 32) protrudes above the plaster (item 2 in Fig. 32).
 - The plaster (item 2 in Fig. 33) protrudes above the plastering trim (item 1 in Fig. 33).

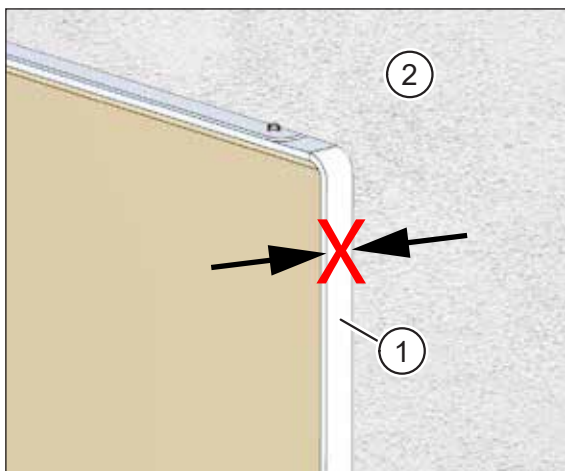

Fig. 32: Plastering trim protrudes over plaster

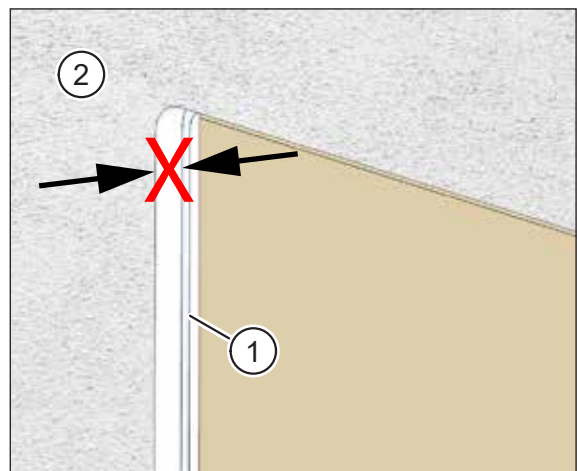

Fig. 33: Plaster protrudes over plastering trim

8.15 Condensate drain on the exhaust air pipe

If M-WRG-II P ventilation units are used, a condensate drain should be provided. The M-WRG-II LR 50-KA set, part no. 735200, with the following components may be used for this purpose:

- Outdoor air pipe, DN 100, 0.5 m (item 1 in Fig. 34)
- Exhaust air pipe, DN 100, 0.5 m (item 2 in Fig. 34), with 1/2" male thread connection (item 3 in Fig. 34) and barrier (item 4 in Fig. 34) for retaining the condensate.

The condensate drain is not needed for M-WRG-II E units under the following conditions:

- The ventilation unit is operated as described in "Intended use" (see section 2.5 on page 10) and the "Rules for correct usage" chapter of the operating instructions.
- There is no exceptional loading due to very high atmospheric humidity.

NOTICE

Note the following points when creating the condensate connection:

- The condensate drain is to be created by the customer.
- Prevent odour transfer by installing an odour trap.
- If possible, connect the condensate drain to a grey water or rainwater discharge.
- In cold regions, protect the condensate drain pipe (item 5 in Fig. 34) against frost, e.g. by running it behind the facade insulation.

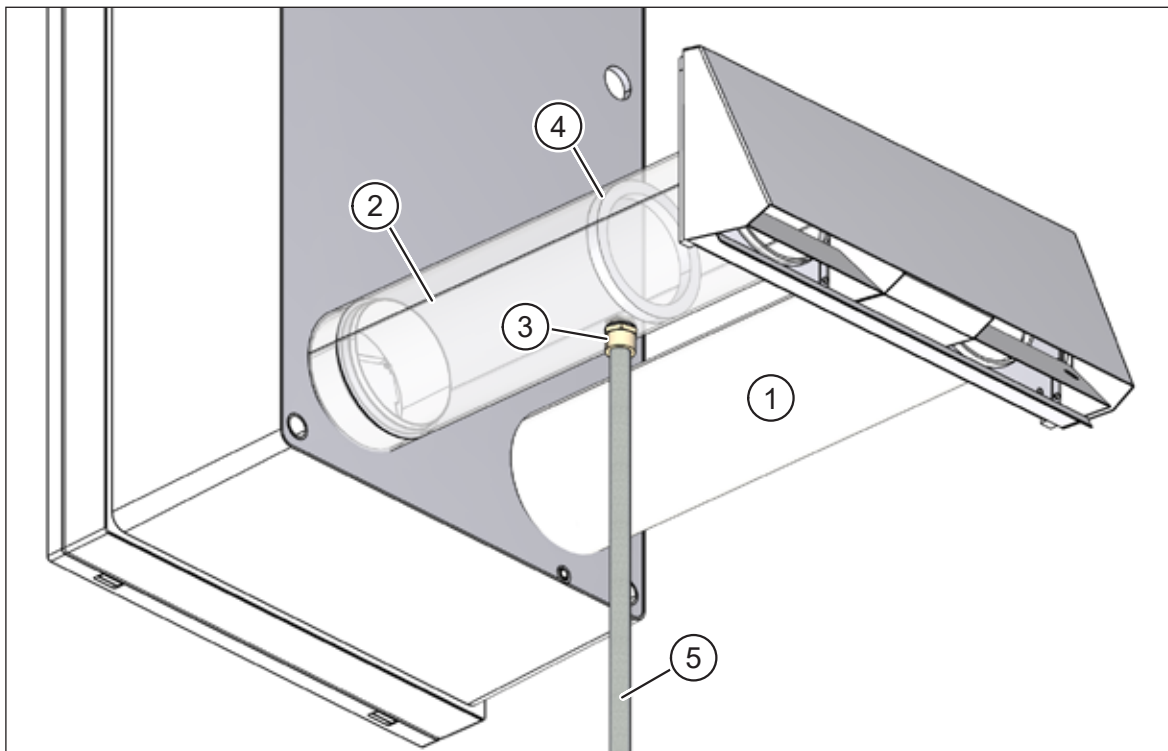

Fig. 34: Condensate drain on the exhaust air pipe

8.16 Aligning the wall box on the outside before plastering

- ▶ Fill the gaps between the wall box and wall breakthrough all around and continuously with expanding foam or using another suitable filling material.

8.16.1 If the solid wall is less than 42.5 cm thick

- ▶ Use a Styrofoam saw to cut off the excess wall box (item 1 in Fig. 35 and Fig. 36) and filler piece, if necessary (item 2 in Fig. 36), so that they are flush with the solid wall or any insulation.

NOTICE

The wall box fixes the ventilation pipes with a 2° fall to the external wall.

- ▶ If the unplastered wall is thin (30 cm or less), do not cut off the wall box flush with the unplastered wall. Allow the wall box to protrude into the external thermal insulation composite system (ETICS) as this is the only way to allow the ventilation pipes to pass far enough through and so be fixed in place.
- ▶ When fitting the ETICS, make sure that the ventilation pipes maintain their 2° fall.

8.16.2 If the solid wall is more than 42.5 cm thick

- ▶ Compensate for thicker walls with continuous pipes. For walls that are 70 cm thick or more, you will need 100 cm long outdoor and exhaust air pipes (M-WRG-LR 100, part no. 5580).

NOTICE

The pipes must be continuous. Pipes that have been joined must not be used as there is a risk of allowing condensation to penetrate the masonry.

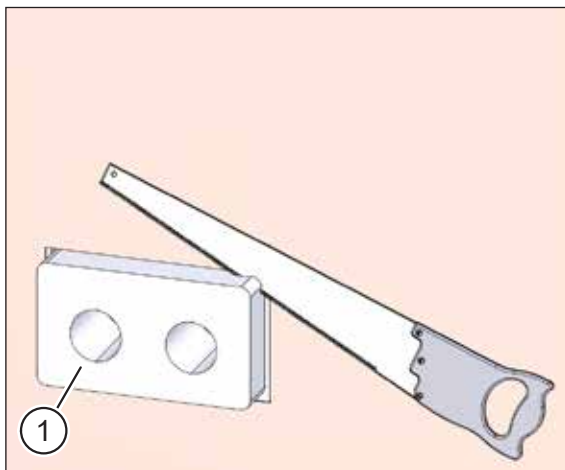

Fig. 35: Aligning the wall box **without** filler piece

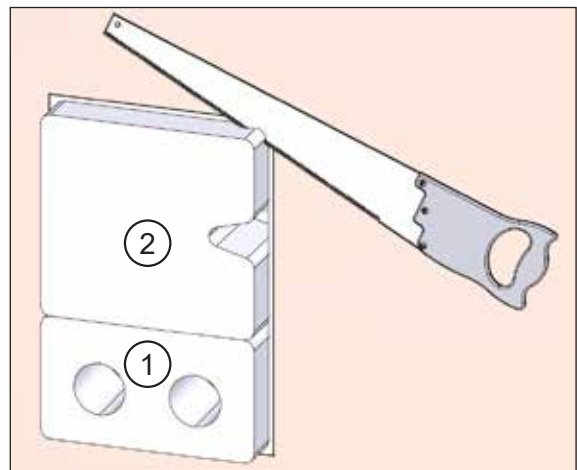

Fig. 36: Aligning the wall box **with** filler piece

8.17 Plastering the installation kit on the outside

- ▶ Insert the protective sleeves (item 1 in Fig. 37 and Fig. 38). They should extend beyond the solid wall so that they will end flush with the subsequent plaster coat. The protective sleeves provide the bonding surface for the external plaster.

NOTICE

- ▶ Prepare the substrate suitably before plastering.
- ▶ Apply the plaster scrim (item 2 in Fig. 37 and Fig. 38) to the outside of the wall box, masonry and/or facade insulation.

NOTICE

Applying plaster scrim will minimise subsequent cracking of the plaster.

- ▶ Plaster the external wall. The plaster forms the windtight layer on the external wall.

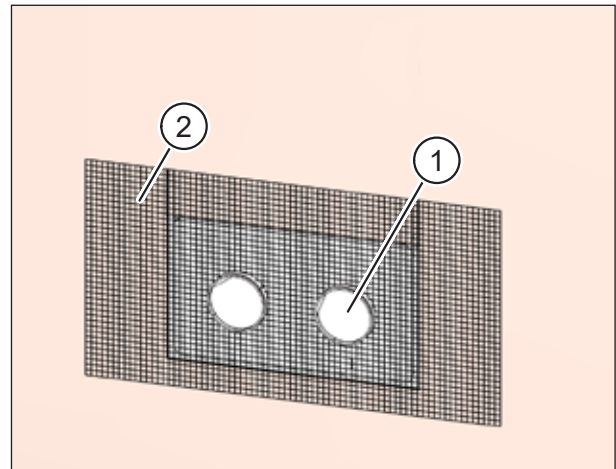

Fig. 37: Plastering the installation kit **without** filler piece

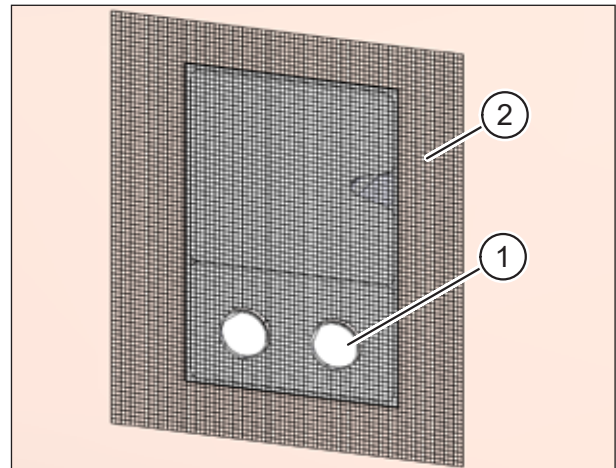

Fig. 38: Plastering the installation kit **with** filler piece

8.18 Preparing the installation kit for connecting the ventilation pipes

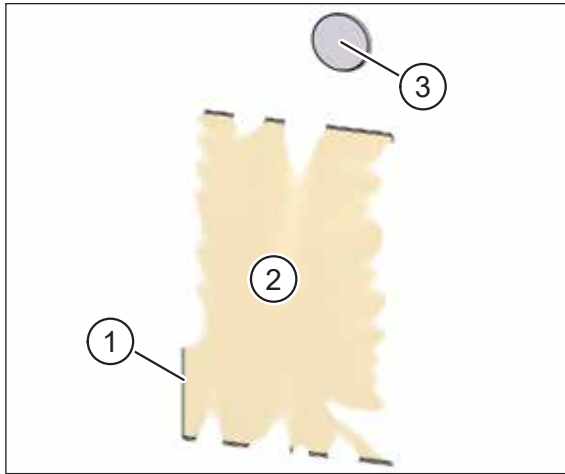

Fig. 39: Installation kit plastered on the inside

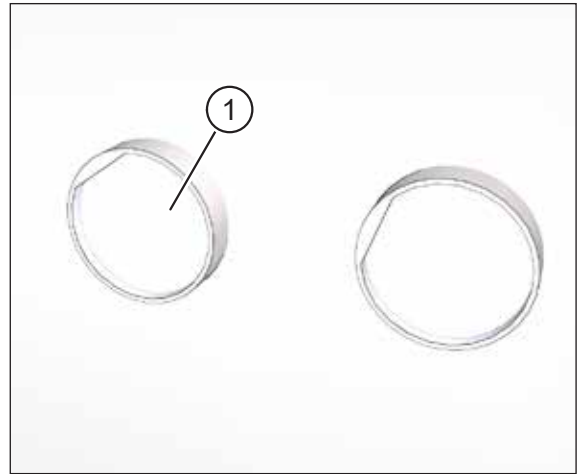

Fig. 40: Installation kit plastered on the outside

— Work on the internal wall:

- ▶ Use a blade to score the plaster on the inside of the plastering trim (item 1 in Fig. 39).
- ▶ Carefully remove the plaster cover (item 2 Fig. 39) and the protective cover lying underneath.
- ▶ Use a blade to score the plaster on the inside of the supply air and extract air openings (item 3 in Fig. 39) and remove the adhesive tape with the plaster.

— Work on the external wall:

- ▶ Remove the two protective sleeves (item 1 in Fig. 40).

8.19 Cutting ventilation pipes to length

- ▶ Push the two ventilation pipes (item 1 in Fig. 41) into the openings in the installation kit until they end flush with the inside of the installation kit (item 2 in Fig. 41).
- ▶ On the outer wall, mark the required excess length of the ventilation pipes to suit the outer wall terminal, see Table 4 on page 37.

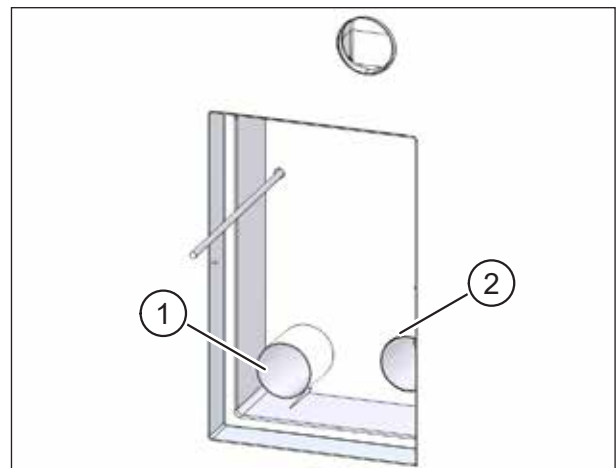

Fig. 41: Cutting ventilation pipes to length

Outer wall terminal	Excess length
Stainless steel pod, M-WRG-II ES	5 - 10 mm from the plastered external wall
Plastic pipe set, M-WRG-II KSR	20 - 27 mm from the plastered external wall

Table 4: Excess length of ventilation pipes protruding from the external wall

- ▶ Remove the ventilation pipes from the openings in the installation kit.
- ▶ Shorten the ventilation pipes to the marked length.
- ▶ Deburr the inner and outer ends of the ventilation pipes.

NOTICE

If you do not deburr the ventilation pipes there is a risk of damaging the seals at the ventilation unit and outer wall terminal.

8.20 Inserting and fixing the ventilation pipes

- ▶ Apply permanently elastic sealant to the outer skin of the ventilation pipes (item 1 in Fig. 42).
- ▶ Push the ventilation pipes back into the openings in the installation kit.
- ▶ Using a twisting motion, push the two ventilation pipes into the openings in the installation kit until they end flush with the inside of the installation kit (item 2 in Fig. 42).
- ▶ Remove any excess sealant.

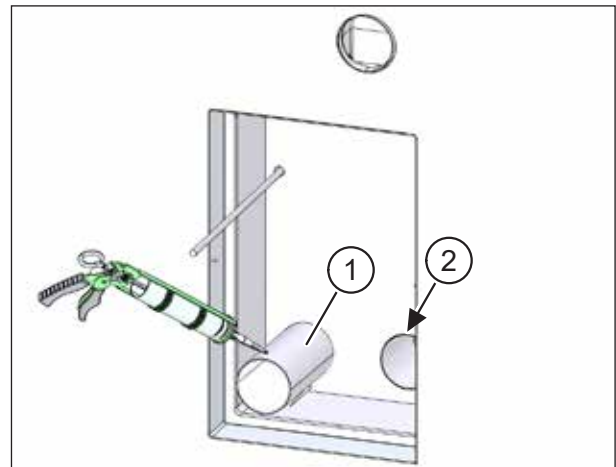

Fig. 42: Inserting and fixing the ventilation pipes

8.21 Sealing ventilation pipes on external wall

NOTICE

If the external plaster encloses the ventilation pipes all round and without gaps, you can skip the steps described in this section.

- ▶ Chamfer both pipe breakthrough edges (item 1 in Fig. 43) to roughly 5 x 45° to create enough space for the sealing joints with permanently elastic sealant.
- ▶ Fill the chamfers of the pipe breakthrough edges all-round with permanently elastic sealant on the outside.

NOTICE

Only use a solvent-free sealant if the sealant is applied to polystyrene.

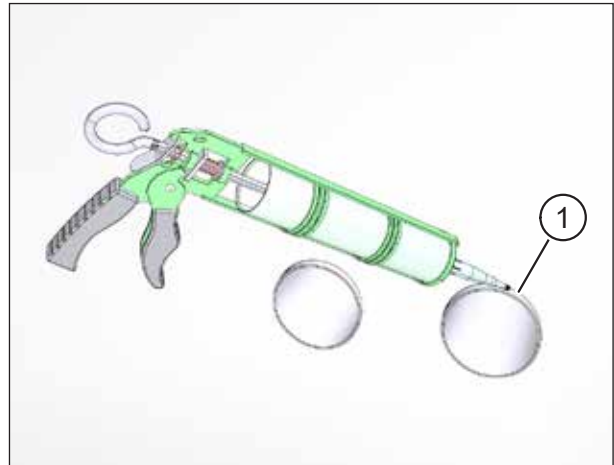

Fig. 43: Sealing ventilation pipes on external wall

8.22 Attaching the outer wall terminal

⚠ WARNING

Do not run without the outer wall terminal.

- ▶ Please note that the ventilation unit must not be used without the outer wall terminal for safety reasons.
- ▶ Attach the outer wall terminal to the external wall.

Installation of the outer wall terminal is described in a separate installation manual (see “1.8 Supplementary documents” on page 7).

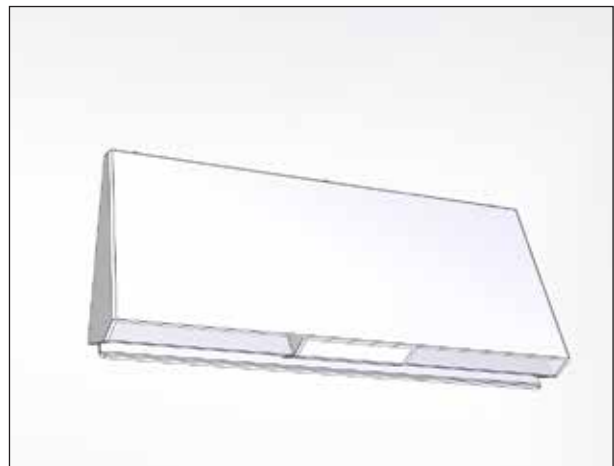

Fig. 44: Attaching the outer wall terminal

9 Installing the installation kit in a frame construction

NOTICE

Frame constructions are implemented in many different ways, so it is not possible to provide a generally-applicable description for every variant. This installation example shows the installation in a frame construction with 160 mm thick framing members. The installation will have to be adapted accordingly for other framing member thicknesses or wall structures.

- ▶ If you are in any doubt, please send us a dimension drawing of your wall section so we can provide you with a custom solution.

9.1 Tools and equipment required

- Permanently elastic sealant, solvent-free if applied to polystyrene
- Sealing tape, 30 mm wide, e.g. Coroplast
- Sealing tape for bonding the wall box to the vapour barrier, e.g. Rissan[®] from SIGA
- Wedges for fixing the wall box, 8 x; if necessary, wedges for fixing the filler piece, 4 x alternatively use inflatable air cushions, e.g. Amo-Bag from Würth, part no. 07156780
- Adhesive tape
- Expanding foam with abP (national technical test certificate of the DIBt) approval ("exact gap" foam is recommended)
- Saw for cutting the ventilation pipes to length
- Saw for cutting the channels in the frame construction
- Styrofoam saw
- Spirit level
- Optionally if the ductwork is riveted to the installation kit:
 - Riveter and blind rivets \varnothing 3 x 6 mm
 - Cordless screwdriver with 3 mm drill bit

9.2 Creating a mount for the installation kit in a frame construction

- ▶ Commission an architect or design professional to include the mount for the installation kit at a suitable point in the construction drawing.
- ▶ Incorporate two wooden battens into the frame construction at the planned installation position:
 - The lower batten (item 1 in Fig. 45) acts as a support.

NOTICE

- ▶ Use a spirit level (item 2 in Fig. 45) to check that the lower batten is exactly horizontal as this is the only way to ensure that any condensation will be carried outside by the 2° pipe fall in the installation kit (item 3 in Fig. 45).

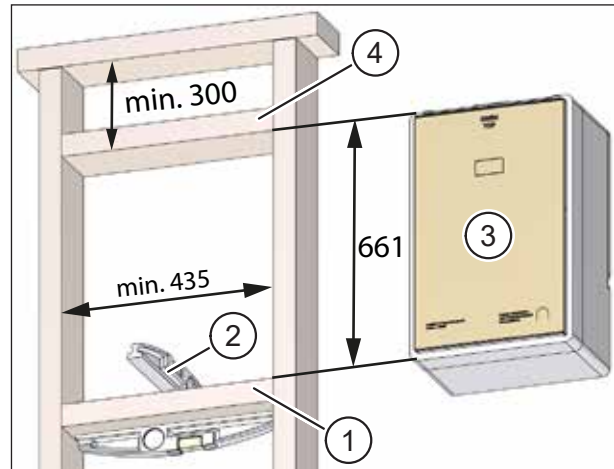

Fig. 45: Creating a mount for the installation kit in a frame construction – dimensions in millimetres

- The upper batten (item 4 in Fig. 45) is used to fix the installation kit.

NOTICE

- The installation kit is fixed in the optimum position with a vertical distance of 661 mm between the lower and upper batten (see Fig. 45). You can insert the installation kit temporarily while fixing the battens to ensure that the kit will fit perfectly.
- Maintain the following minimum distances:
 - At least 435 mm between the vertical framing members
 - At least 300 mm between the top edge of the wall box and the ceiling
 - At least 50 mm between the side and bottom edges of the wall box and adjacent surfaces

9.3 Sawing channels for flat ductwork or flexible pipes

NOTICE

With this installation kit you can connect to the extract air and supply air openings using either flat ductwork or flexible pipe. The installation example shown in this section is a configuration with two flat ductwork connections. Section 8.3 from page 21 contains further variants that can also be used for installation in frame constructions.

- ▶ Saw two channels for the extract air duct (item 3 in Fig. 46) and supply air duct (item 4 in Fig. 46) in the upper batten (item 1 in Fig. 46) and the ceiling joist (item 2 in Fig. 46).
- ▶ Check that the installation kit fits easily into the space.
- ▶ If necessary, saw channels for the rest of the flat ductwork as shown in your plans.

NOTICE

The dimensions of the channels for the flat ducts are:

- 120 mm wide
- 60 mm deep

The dimensions of the channels for the flexible pipes are:

- 175 mm wide
- 85 mm deep

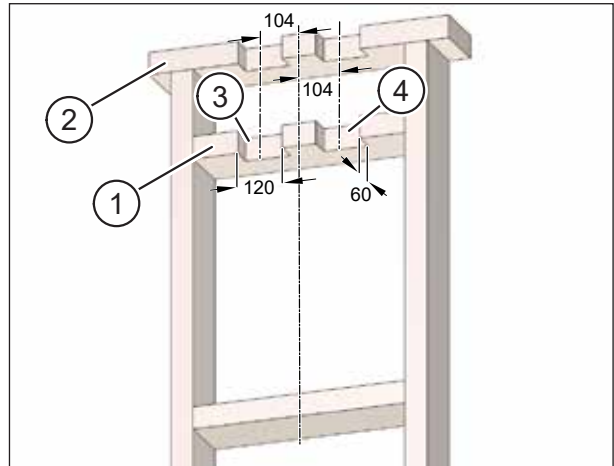

Fig. 46: Sawing channels for flat ductwork, dimensions in millimetres

NOTICE

- ▶ Observe the following recommendations when using flexible pipes to avoid unnecessary pressure losses in the pipes.
 - Always connect two flexible pipes to the flexible pipe connection.
 - As far as possible, use flexible pipes with a diameter of 75 mm.
 - The total length of each flexible pipe should not exceed 10 m.
 - Minimise the number of bends in the flexible pipes.
 - Run the two flexible pipes of a flexible pipe connection in parallel to one another. The minimum distance between the flexible pipes must not be less than 3 x the pipe diameter.

9.4 Running the mains and control cables

⚠ DANGER

Potentially fatal voltages

- The electrical installation work must only be carried out by a qualified electrician.
- The VDE regulations or any special safety regulations applicable in your country apply to the electrical installation work.
- ▶ Before starting installation or maintenance work, disconnect the mains cable for connecting to the ventilation unit on all poles from the mains supply.
- ▶ Observe the five safety rules (DIN VDE 0105-100, EN 50110-1) for working on electrical systems:
 - Disconnect from mains (all-pole disconnection of a system from live parts)
 - Secure against reconnection
 - Check that the system is voltage-free
 - Earth and short-circuit
 - Cover or block off access to adjacent live parts

- ▶ Run the mains cable (item 1 in Fig. 47) and the control cable, if required (item 2 in Fig. 47). The cables should extend roughly 250 mm beyond the wall.
- ▶ Fix the mains cable and the control cable (if used) in position.

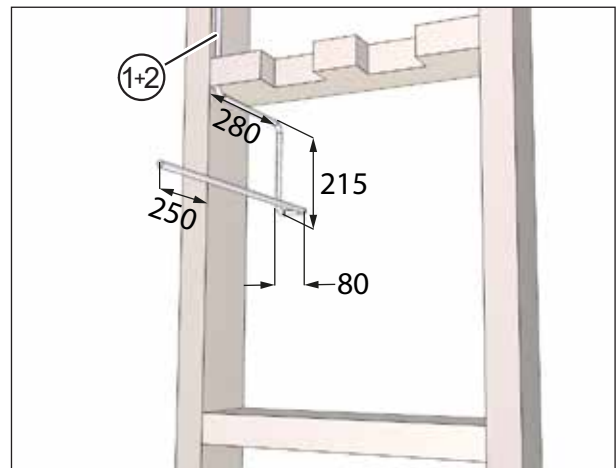

Fig. 47: Running the connecting cables, dimensions in millimetres

NOTICE

- Table 5 on page 43 and Table 6 on page 45 contain overviews of the recommended types of mains cable and control cable.
- A control cable is only needed for certain types of ventilation unit.
- The ventilation unit is equipped with an external control input as standard. The mains cable **NYM-J 4x1.5 mm²** is needed if this control input is used.

9.4.1 Cable types

Part no.	Type of ventilation unit	Type of mains cable	Type of control cable
700000 (*) 700001 (*) 700002 (*) 701000 (*) 701001 (*) 701002 (*)	M-WRG-II P M-WRG-II P-F M-WRG-II P-FC M-WRG-II E M-WRG-II E-F M-WRG-II E-FC	NYM-J 3x1.5 mm ² or NYM-J 4x1.5 mm ² (**)	No control cable
700010 700011 700012 701010 701011 701012	M-WRG-II P-T M-WRG-II P-T-F M-WRG-II P-T-FC M-WRG-II E-T M-WRG-II E-T-F M-WRG-II E-T-FC	NYM-J 3x1.5 mm ² or NYM-J 4x1.5 mm ² (**)	— InControl pushbutton sensor: J-Y (St) Y 10x2x0.6 mm / J-Y (St) Y 10x2x0.8 mm — Three-step rotary switch: J-Y (St) Y 4x2x0.6 mm / J-Y (St) Y 4x2x0.8 mm — BCD encoding: J-Y (St) Y 4x2x0.6 mm / J-Y (St) Y 4x2x0.8 mm
700020 700021 700022 701020 701021 701022	M-WRG-II P-M M-WRG-II P-M-F M-WRG-II P-M-FC M-WRG-II E-M M-WRG-II E-M-F M-WRG-II E-M-FC	NYM-J 3x1.5 mm ² or NYM-J 4x1.5 mm ² (**)	Building management system, Modbus, Loxone, KNX: J-Y (St) Y 2x2x0.6 mm / J-Y (St) Y 2x2x0.8 mm
700030 700031 700032 701030 701031 701032	M-WRG-II P-S 485 M-WRG-II P-S 485-F M-WRG-II P-S 485-FC M-WRG-II E-S 485 M-WRG-II E-S 485-F M-WRG-II E-S 485-FC	NYM-J 3x1.5 mm ² or NYM-J 4x1.5 mm ² (**)	Touch Control network: J-Y (St) Y 2x2x0.6 mm / J-Y (St) Y 2x2x0.8 mm

Table 5: Types of mains cable and control cable for each ventilation unit type

(*) If you install these types of ventilation unit in the M-WRG-II M-U² installation kit, we recommend that you use the following options to operate the ventilation units:

- Using the app via the gateway M-WRG-GW, part no. 5453-00
- Wireless remote control M-WRG-FBH, part no. 5478-10
- 4-way wireless pushbutton switch M-WRG-FT, part no. 5478-20
- External wireless humidity sensor M-WRG-II FSF, part no. 733010
- External wireless CO₂ sensor M-WRG-II FSC, part no. 733011

(**) If the external control input is used

9.4.2 External control input

With the external control input supplied as standard, the M-WRG-II unit has an additional input terminal for 230 V AC (working voltage range: 85 V AC to 265 V AC / 50 - 60 Hz) to which a switch, time switch, motion detector or similar may be connected.

The external control input is equipped with a time-delay relay that can be used to set a switch-on delay and a run-on time:

- Switch-on delay: the M-WRG-II unit does not start until the set time has elapsed.
- Run-on time: the M-WRG-II unit does not switch to the previously active ventilation program until the set time has elapsed.

In addition, the following options are available for the external control input supplied as standard:

- M-WRG-II O/EST-1 (without switch-on delay, part no. 721005)
- M-WRG-II O/EST-2 (without run-on time, part no. 721006)

Windowless rooms can be ventilated in accordance with DIN 18017-3 in combination with the M-WRG-II O/NOF option (part no. 721004).

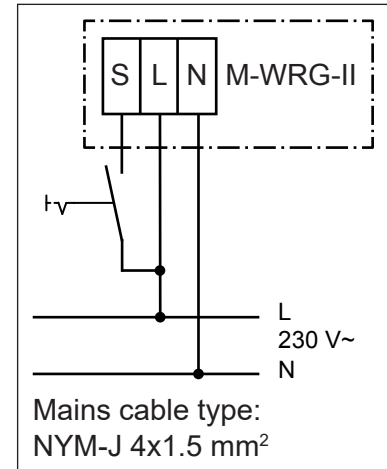

Fig. 48: Connection diagram for external control input

9.4.3 Option M-WRG-II O/EGG-AUS

Part no.	Option M-WRG-II O/EGG-AUS	Type of control cable
721003	“Unit OFF” input, e.g. via an external smoke detector or window contact	J-Y (St) Y 2x2x0.6 mm / J-Y (St) Y 2x2x0.8 mm
	Potential-free fault indicator output	J-Y (St) Y 2x2x0.6 mm / J-Y (St) Y 2x2x0.8 mm

Table 6: Option M-WRG-II O/EGG-AUS

The connection board for the M-WRG-II O/EGG-AUS option has 5 terminals (see Fig. 49):

- 3-pole connection for fault indicator output
- 2-pole connection for “Unit OFF” input

We recommend that you use separate cables for the input and output.

NOTICE

The M-WRG-II O/EGG-AUS option must be installed at the factory.

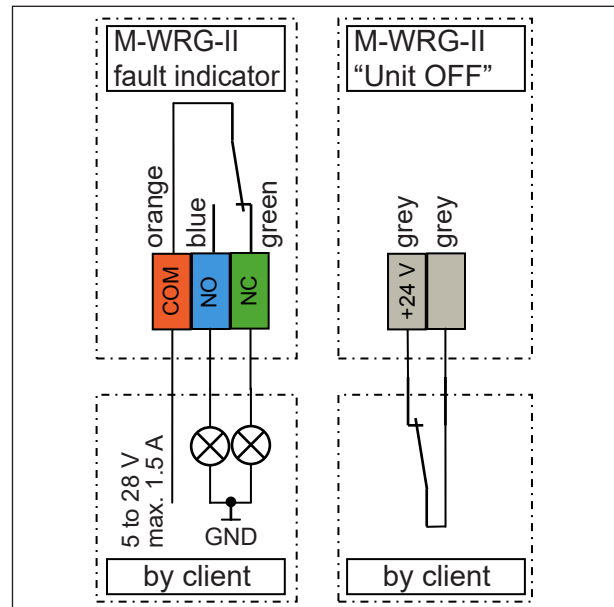

Fig. 49: Connection diagrams for M-WRG-II O/EGG-AUS option

9.5 Inserting and fixing the wall box

- ▶ Remove the plaster cover (item 1 in Fig. 50) and the protective cover (item 2 in Fig. 50) from the wall box (item 3 in Fig. 50).
- ▶ Apply assembly adhesive to the top of the lower batten (item 4 in Fig. 50) and the underside of the upper batten (item 5 in Fig. 50).

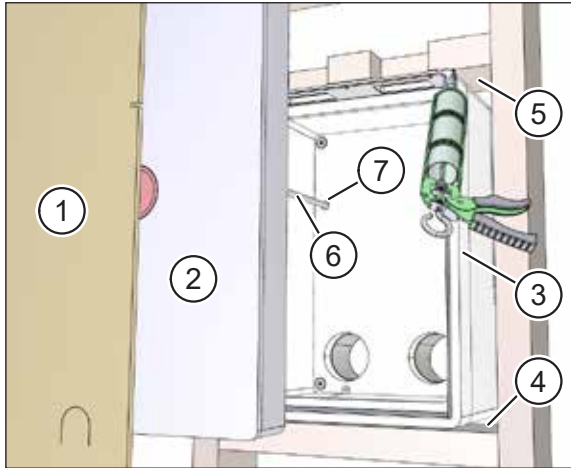

Fig. 50: Inserting and fixing the wall box

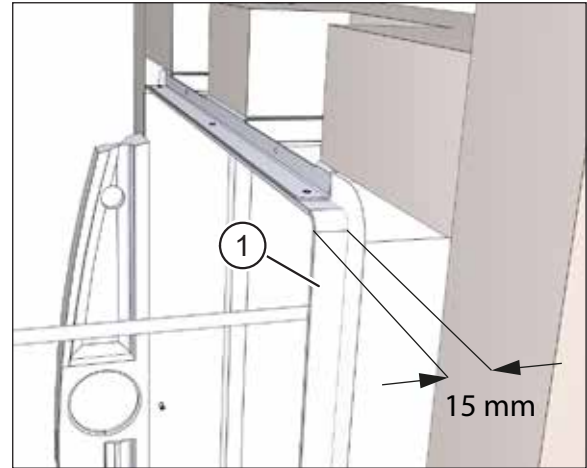

Fig. 51: Depth of plastering trim 15 mm

- ▶ Thread the mains cable and the control cable, if required (item 6 in Fig. 50), through the cable inlet in the wall box (item 7 in Fig. 50).
- ▶ Push the wall box between the two battens so that the plastering trim (item 1 in Fig. 51) will end flush with the eventual internal wall cladding (e.g. OSB board + plasterboard) or so that the internal wall cladding will protrude slightly above the plastering trim (see section A-A and detail D in Fig. 52 and Fig. 62 on page 51).

NOTICE

- The plastering trim is 15 mm deep (see Fig. 51).
- The plastering trim must NOT protrude above the eventual internal wall cladding (see Fig. 61 on page 51) otherwise there will be an unsightly gap between the plastering trim and the unit cover (U² cover).
- Make sure that the wall box is perpendicular as this is the only way to ensure that any condensation will be carried outside by the 2° pipe fall.

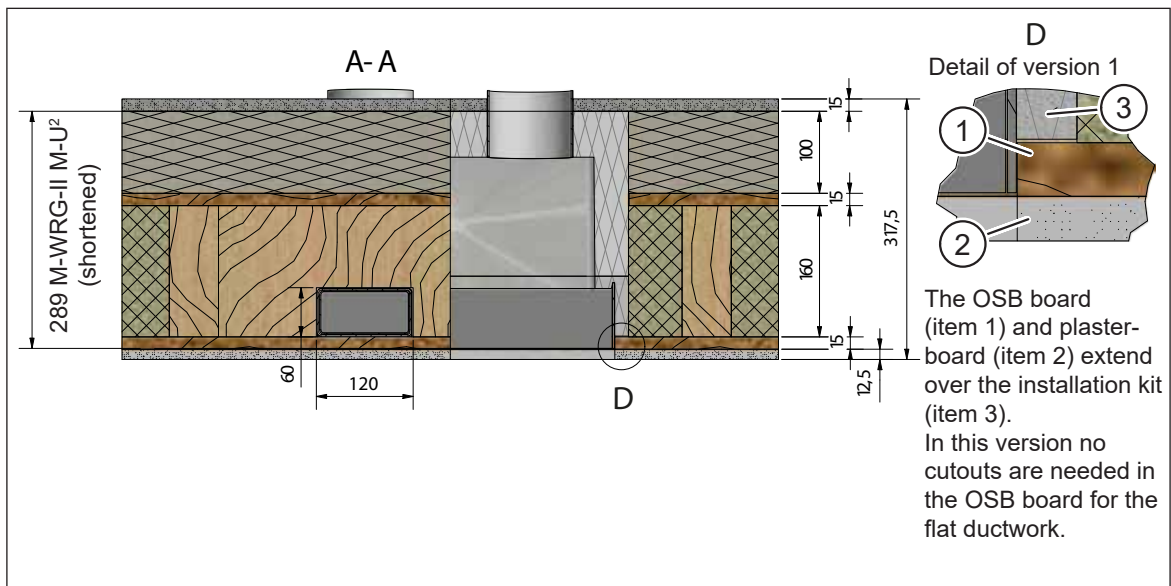

Fig. 52: Plastering trim and internal wall cladding ending flush

9.6 Inserting the protective cover and plaster cover

- ▶ Insert the protective cover (item 1 in Fig. 53) into the wall box (item 3 in Fig. 53).

NOTICE

There is a risk that the wall box will be deformed during the remainder of the installation process if the protective cover is not inserted. If this happens, it will not be possible to insert the ventilation unit into the wall box.

- ▶ Insert the plaster cover (item 2 in Fig. 53) into the wall box (item 3 in Fig. 53) as far as it will go.

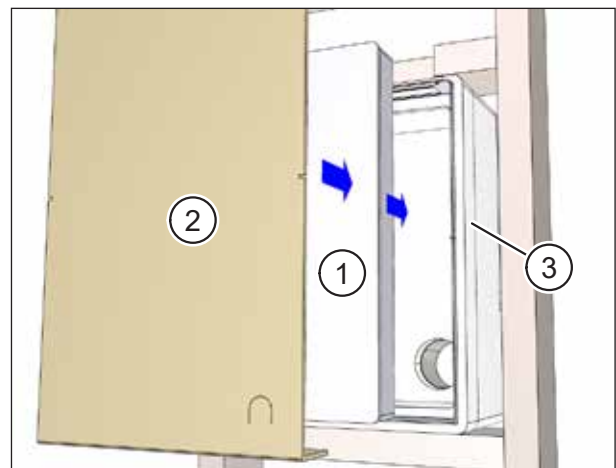

Fig. 53: Inserting the protective cover and plaster cover

9.7 Filling gaps around the wall box with insulating material

- Fill all gaps between the wall box and frame construction fully with insulating material (item 1 in Fig. 54) or using another suitable filling material. Be careful not to block the extract air and supply air openings at the top of the wall box.

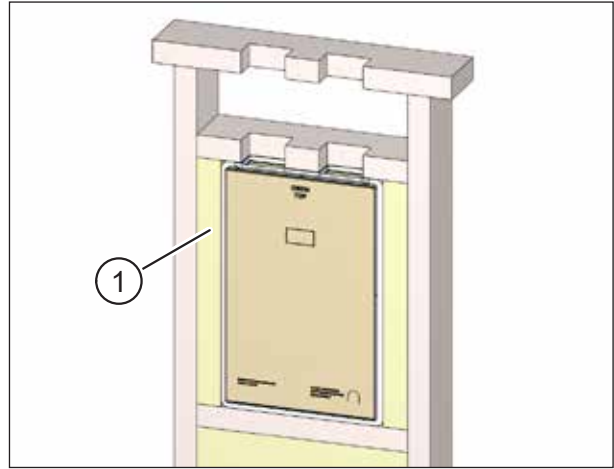

Fig. 54: Filling gaps around the wall box with insulating material

9.8 Connecting the wall box to the vapour barrier

The inner OSB board (item 1 in Fig. 55) is the vapour barrier and airtight layer. The OSB board must be connected to the wall box using a suitable and approved adhesive tape, e.g. Rissan[®] from SIGA.

Other wall structures may require different procedures.

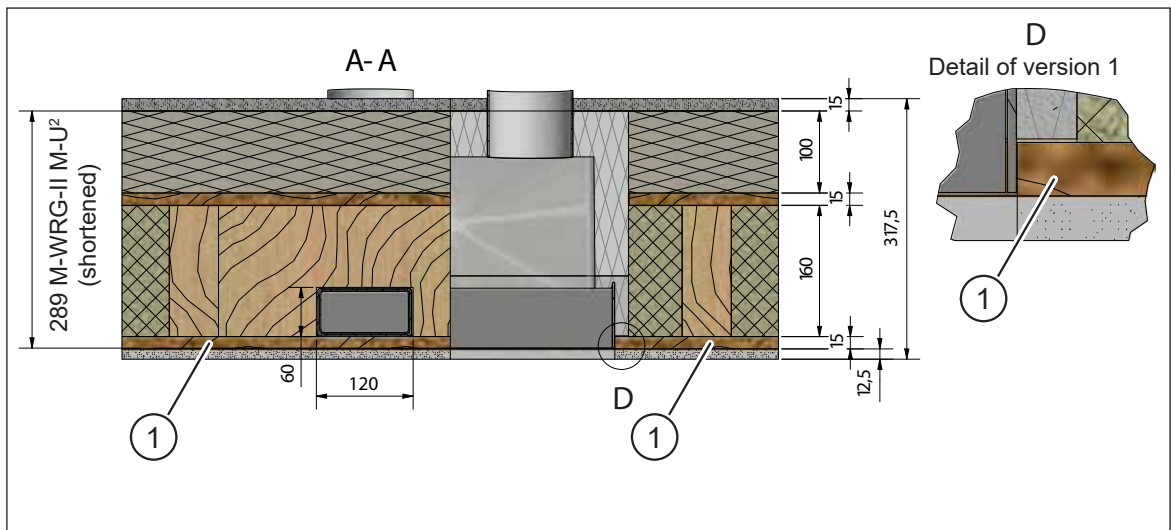

Fig. 55: Inner OSB board as the vapour barrier and airtight layer

9.9 Inserting flat ductwork into channels

NOTICE

If you are using flexible pipes, continue from section “8.11 Cutting flexible pipes to length” on page 30.

- ▶ Insert a fitting, e.g. the flat ductwork connector M-WRG-FK-V, part no. 5591 (item 1 in Fig. 27), into the opening in the wall box.

NOTICE

All fittings (flat ductwork connectors, bends, angles, etc.) inserted into the opening in the wall box must have the external dimensions 115 x 58 mm. Elements with the external dimensions 110 x 54 mm, e.g. flat ductwork, are designed to be inserted into the fittings. They must not be inserted directly into the opening in the wall box.

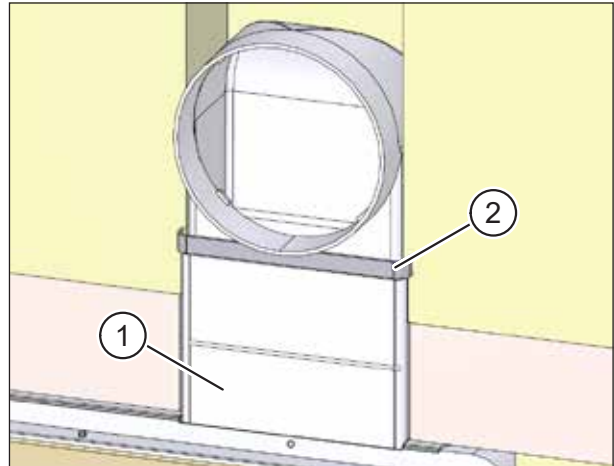

Fig. 56: Fixing ductwork connections with sealing tape

- ▶ Join individual elements of the flat ductwork to create partial sections and seal every joint with a layer of sealing tape 30 mm wide.
- ▶ Insert the first section of the flat ductwork into the fitting, e.g. the flat ductwork connector M-WRG-FK-V, part no. 5591, on the wall box and seal the joint with sealing tape (item 2 in Fig. 27).
- ▶ Insert the sections of flat ductwork into the channel one after another and seal every joint with sealing tape.
- ▶ Fill the gaps around the flat ductwork with insulating material or other suitable filling materials. This will improve both the seal and the insulation.

9.10 Cutting flexible pipes to length

- ▶ Remove the red protective cover (item 1 in Fig. 57) from the flexible pipe connection (item 3 in Fig. 57).
- ▶ Shorten the flexible pipes (item 2 in Fig. 57) so that the flexible pipe connection (item 3 in Fig. 57) with the flexible pipes inserted can be pushed into the opening on the wall box.

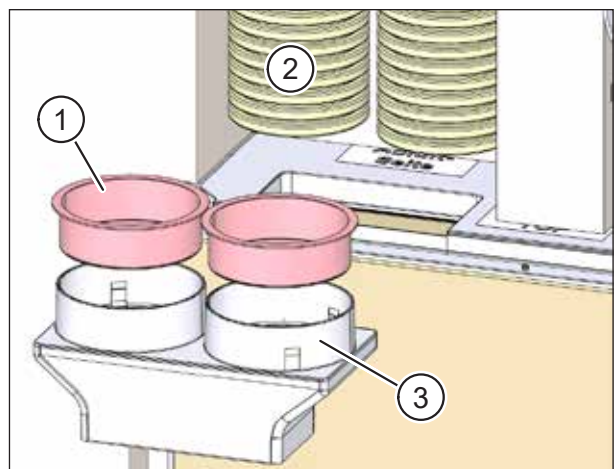

Fig. 57: Cutting flexible pipes to length

9.11 Inserting flexible pipes into the flexible pipe connection

- ▶ Insert the sealing rings (item 1 in Fig. 58) into the second groove on the flexible pipe. These are available as accessories M-WRG-FR-DR75 (part no. 5056-41/75) or M-WRG-FR-DR63 (part no. 5056-41/63) for the corresponding diameters.
- ▶ Insert the flexible pipes into the openings in the flexible pipe connection. Make sure that the first groove on the flexible pipe (item 2 in Fig. 58) engages with the locking ring (item 3 in Fig. 58) on the flexible pipe connection.
- ▶ Recommendation: Seal the join with a layer of sealing tape 30 mm wide (item 4 in Fig. 58).
- ▶ Insert the flexible pipe connection (item 5 in Fig. 58) into the opening in the wall box.

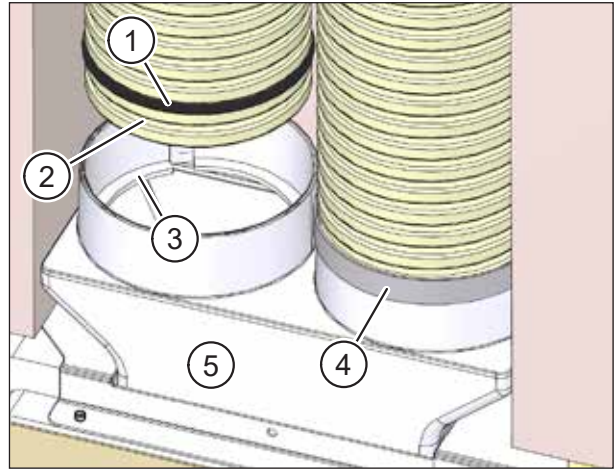

Fig. 58: Fixing a flexible pipe connection with sealing tape

NOTICE

- ▶ Run the flexible pipes without forcing or stresses.
- ▶ Fix the flexible pipes in place with expanding foam or insulating material.

9.12 Fixing the connections for flat ductwork/flexible pipe to the wall box

There are two holes (item 1 in Fig. 59) in the plastering trim for fixing the flat ductwork or flexible pipe connections to the wall box with blind rivets if necessary. These holes will also need to be drilled in the flat ductwork or flexible pipe connections.

- ▶ Use the 3 mm drill bit to drill through the holes in the plastering trim (item 1 in Fig. 59) and into the flat ductwork or flexible pipe connections.
- ▶ Use the riveter to fix the flat ductwork or flexible pipe connection to the plastering trim for the wall box.

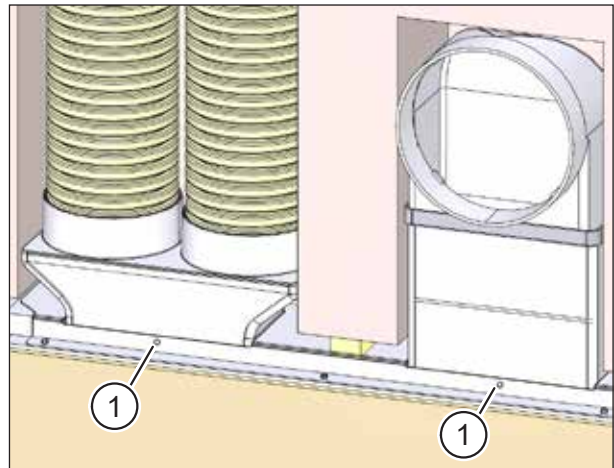

Fig. 59: Fixing the connections for flat ductwork/flexible pipe to the wall box

9.13 Cladding the installation kit and flat ductwork / flexible pipes on the inside

In this installation example, the inside is cladded with OSB board and plasterboard.

- ▶ Make sure that the plaster cover (item 1 in Fig. 60) is seated in the wall box.
- ▶ Make a cutout with the same dimensions as the plastering trim (item 4 in Fig. 60) in the OSB board (item 2 in Fig. 60) and the plasterboard (item 3 in Fig. 60).
- ▶ Place the OSB board on the plastering trim and fix it to the frame construction.
- ▶ Align the cutout in the plasterboard with the cutout in the OSB board and fix the plasterboard in position.
- ▶ When fitting the cladding note the following points:
 - The plastering trim (item 1 in Fig. 61) must NOT protrude above the plasterboard (item 2 in Fig. 61).
 - The plasterboard (item 2 in Fig. 62) must NOT protrude more than 15 mm above the plastering trim (item 1 in Fig. 62).

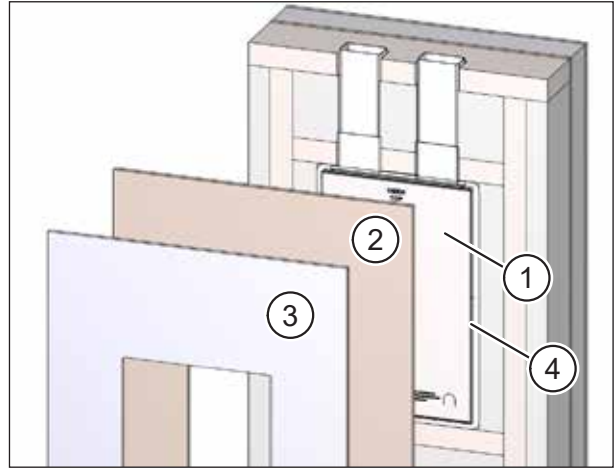

Fig. 60: Cladding the installation kit and flat ductwork / flexible pipes on the inside

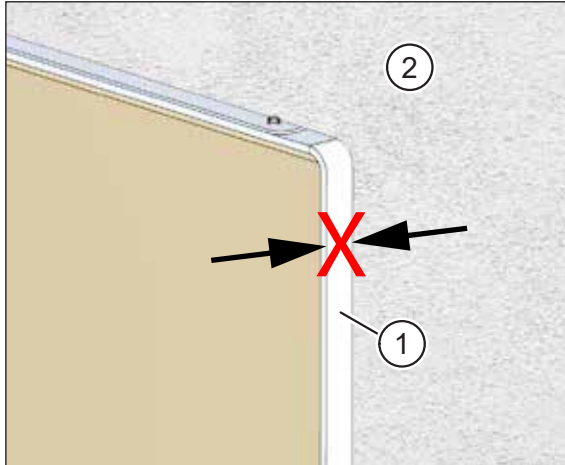

Fig. 61: The plastering trim must NOT protrude above the cladding

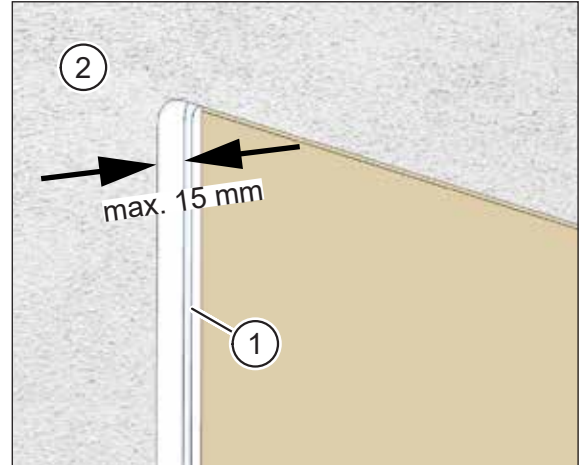

Fig. 62: The cladding must not protrude more than 15 mm

9.14 Condensate drain on the exhaust air pipe

If M-WRG-II P ventilation units are used, a condensate drain should be provided. The M-WRG-II LR 50-KA set, part no. 735200, with the following components may be used for this purpose:

- Outdoor air pipe, DN 100, 0.5 m (item 1 in Fig. 63)
- Exhaust air pipe, DN 100, 0.5 m (item 2 in Fig. 63), with 1/2" male thread connection (item 3 in Fig. 63) and barrier (item 4 in Fig. 63) for retaining the condensate.

The condensate drain is not needed for M-WRG-II E units under the following conditions:

- The ventilation unit is operated as described in "Intended use" (see section 2.5 on page 10) and the "Rules for correct usage" chapter of the operating instructions.
- There is no exceptional loading due to very high atmospheric humidity.

NOTICE

Note the following points when creating the condensate connection:

- The condensate drain is to be created by the customer.
- Prevent odour transfer by installing an odour trap.
- If possible, connect the condensate drain to a grey water or rainwater discharge.
- In cold regions, protect the condensate drain pipe (item 5 in Fig. 63) against frost, e.g. by running it behind the facade insulation.

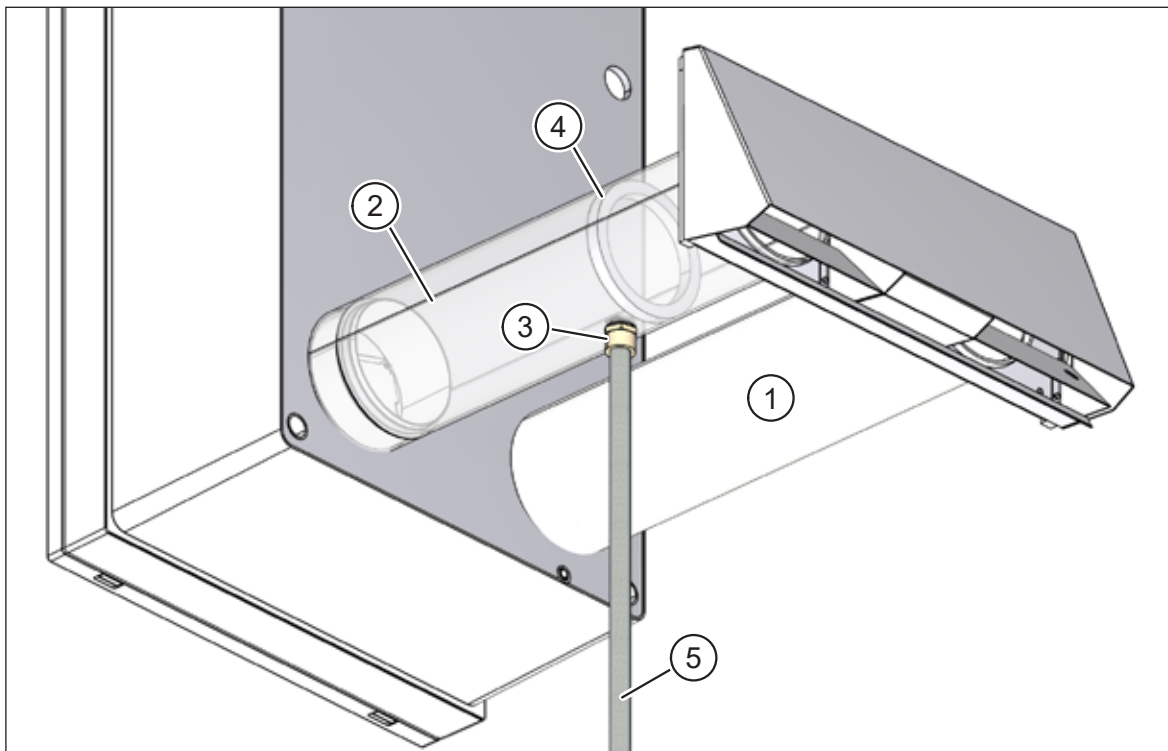

Fig. 63: Condensate drain on the exhaust air pipe

9.15 Aligning the wall box on the outside before plastering

- ▶ Fill the gaps between the wall box and frame construction all around and continuously with insulating material or other suitable filling materials.

9.15.1 If the wall is less than 42.5 cm thick

- ▶ Use a Styrofoam saw to cut off the excess wall box (item 1 in Fig. 64 and Fig. 65) and filler piece, if necessary (item 2 in Fig. 65), so that they are flush with the external wall side or any attached insulation.

NOTICE

The wall box fixes the ventilation pipes with a 2° fall to the external wall.

- ▶ The installation kit can be shortened by up to 165 mm (to no less than 273 mm). Allow the kit to protrude into the external thermal insulation composite system (ETICS) as this is the only way to allow the ventilation pipes to pass far enough through and so be fixed in place.
- ▶ When fitting the ETICS, make sure that the ventilation pipes maintain their 2° fall.

9.15.2 If the wall is more than 42.5 cm thick

- ▶ Compensate for thicker walls with continuous pipes. For walls that are 70 cm thick or more, you will need 100 cm long outdoor and exhaust air pipes (M-WRG-LR 100, part no. 5580).

NOTICE

The pipes must be continuous. Pipes that have been joined must not be used as there is a risk of allowing condensation to penetrate into the frame construction.

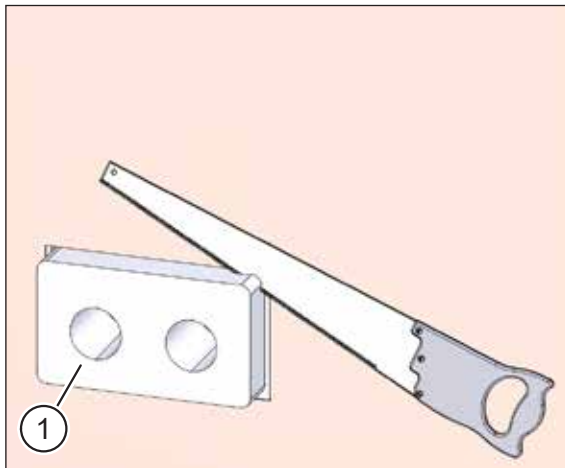

Fig. 64: Aligning the wall box **without** filler piece

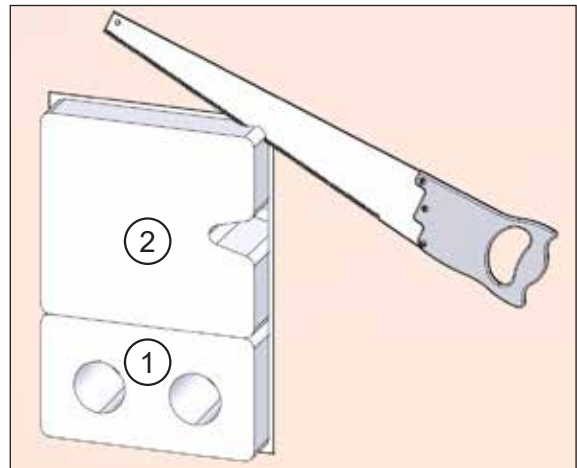

Fig. 65: Aligning the wall box **with** filler piece

9.16 Plastering the installation kit on the outside

- ▶ Insert the protective sleeves (item 1 in Fig. 66 and Fig. 67). They should extend beyond the external wall so that they will end flush with the subsequent plaster coat. The protective sleeves provide the bonding surface for the external plaster.

NOTICE

- ▶ Prepare the substrate suitably before plastering.
- ▶ Apply the plaster scrim (item 2 in Fig. 66 and Fig. 67) to the outside of the wall box, external wall and/or facade insulation.

NOTICE

Applying plaster scrim will minimise subsequent cracking of the plaster.

- ▶ Plaster the external wall. The plaster forms the windtight layer on the external wall.

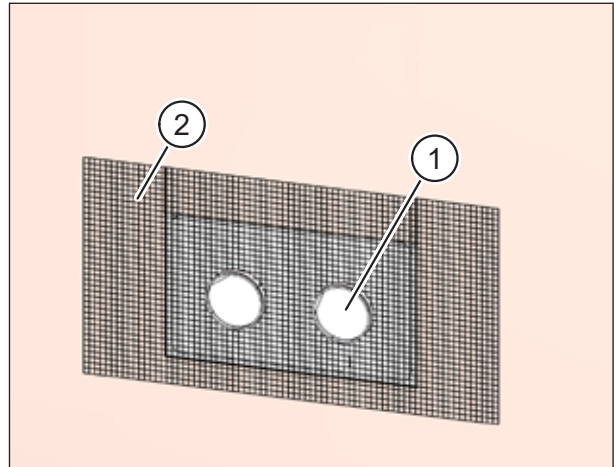

Fig. 66: Plastering the installation kit **without** filler piece

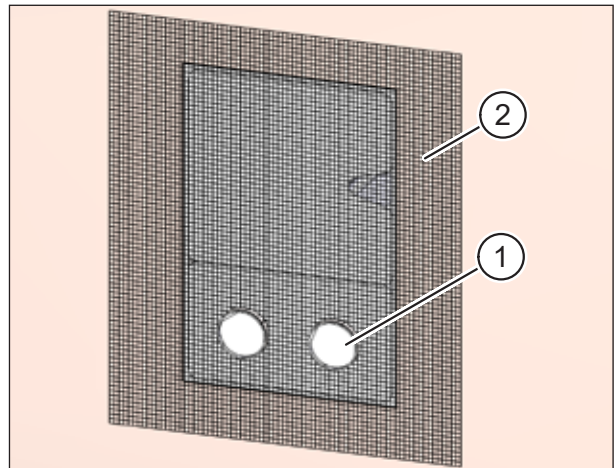

Fig. 67: Plastering the installation kit **with** filler piece

9.17 Preparing the installation kit for connecting the ventilation pipes

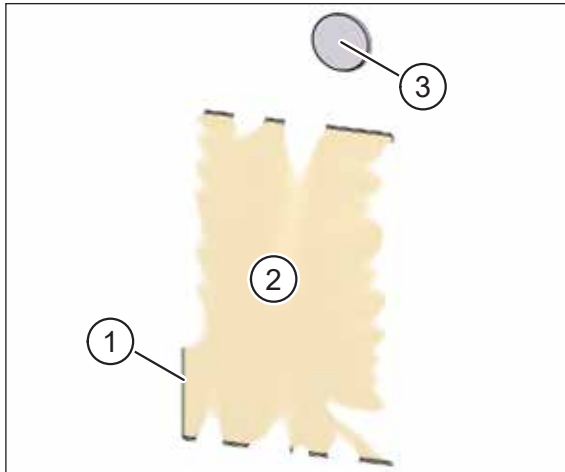

Fig. 68: Installation kit plastered on the inside

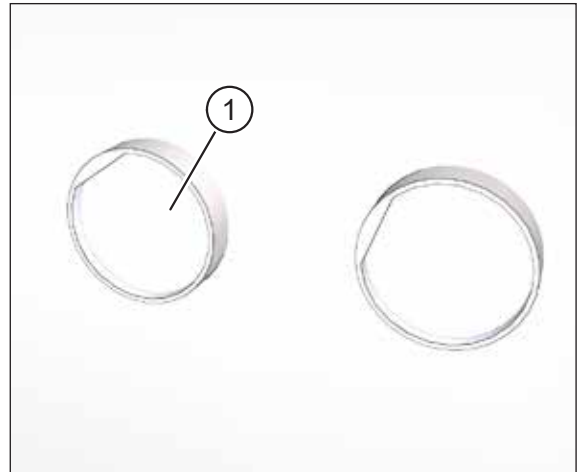

Fig. 69: Installation kit plastered on the outside

— Work on the internal wall:

- ▶ Use a blade to score the plaster on the inside of the plastering trim (item 1 in Fig. 68).
- ▶ Carefully remove the plaster cover (item 2 Fig. 68) and the protective cover lying underneath.
- ▶ Use a blade to score the plaster on the inside of the supply air and extract air openings (item 3 in Fig. 68) and remove the adhesive tape with the plaster.

— Work on the external wall:

- ▶ Remove the two protective sleeves (item 1 in Fig. 69).

9.18 Cutting ventilation pipes to length

- ▶ Push the two ventilation pipes (item 1 in Fig. 70) into the openings in the installation kit until they end flush with the inside of the installation kit (item 2 in Fig. 70).
- ▶ On the outer wall, mark the required excess length of the ventilation pipes to suit the outer wall terminal, see Table 7 on page 56.

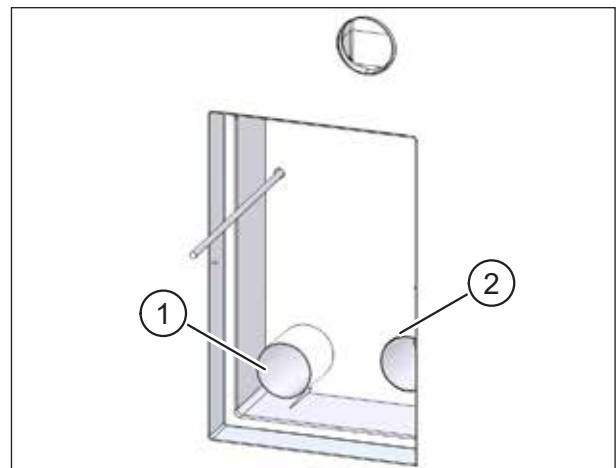

Fig. 70: Cutting ventilation pipes to length

Outer wall terminal	Excess length
Stainless steel pod, M-WRG-II ES	5 - 10 mm from the plastered external wall
Plastic pipe set, M-WRG-II KSR	20 - 27 mm from the plastered external wall

Table 7: Excess length of ventilation pipes protruding from the external wall

- ▶ Remove the ventilation pipes from the openings in the installation kit.
- ▶ Shorten the ventilation pipes to the marked length.
- ▶ Deburr the inner and outer ends of the ventilation pipes.

NOTICE

If you do not deburr the ventilation pipes there is a risk of damaging the seals at the ventilation unit and outer wall terminal.

9.19 Inserting and fixing the ventilation pipes

- ▶ Apply permanently elastic sealant to the outer skin of the ventilation pipes (item 1 in Fig. 71).
- ▶ Push the ventilation pipes back into the openings in the installation kit.
- ▶ Using a twisting motion, push the two ventilation pipes into the openings in the installation kit until they end flush with the inside of the installation kit (item 2 in Fig. 71).
- ▶ Remove any excess sealant.

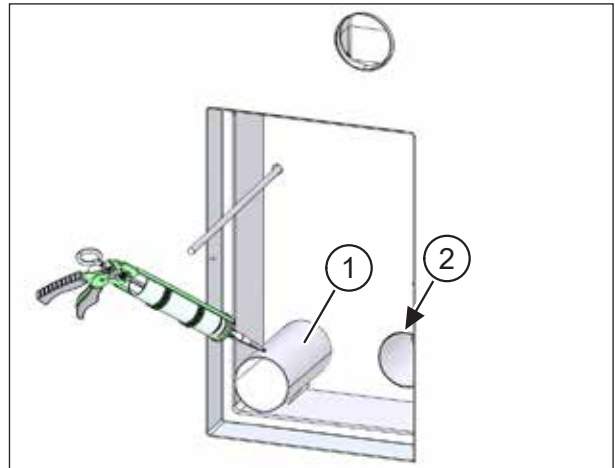

Fig. 71: Inserting and fixing the ventilation pipes

9.20 Sealing ventilation pipes on external wall

NOTICE

If the external plaster encloses the ventilation pipes all round and without gaps, you can skip the steps described in this section.

- ▶ Chamfer both pipe breakthrough edges (item 1 in Fig. 72) to roughly 5 x 45° to create enough space for the sealing joints with permanently elastic sealant.
- ▶ Fill the chamfers of the pipe breakthrough edges all-round with permanently elastic sealant on the outside.

NOTICE

Only use a solvent-free sealant if the sealant is applied to polystyrene.

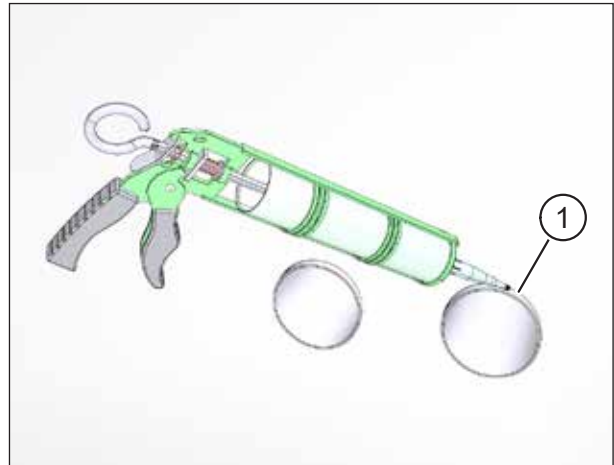

Fig. 72: Sealing ventilation pipes on external wall

9.21 Attaching the outer wall terminal

⚠ WARNING

Do not run without the outer wall terminal.

- ▶ Please note that the ventilation unit must not be used without the outer wall terminal for safety reasons.
- ▶ Attach the outer wall terminal to the external wall.

Installation of the outer wall terminal is described in a separate installation manual (see “1.8 Supplementary documents” on page 7).

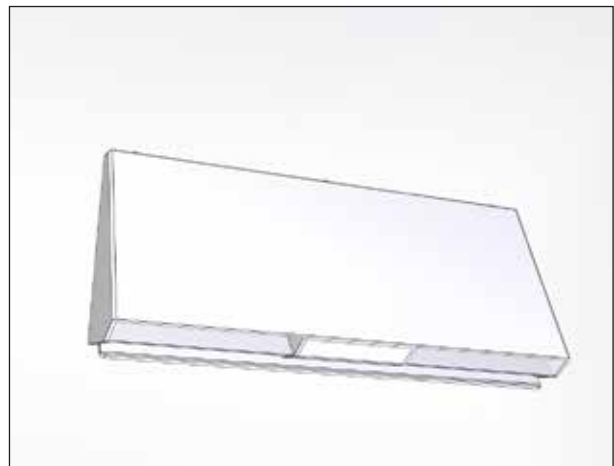

Fig. 73: Attaching the outer wall terminal

10 Installing the ventilation unit

NOTICE

Installation of the ventilation unit in the installation kit is described in the "M-WRG-II ventilation unit installation manual", part no. 744004EN.



Fig. 74: Ventilation unit installed

11 Installation example for installation in a solid wall

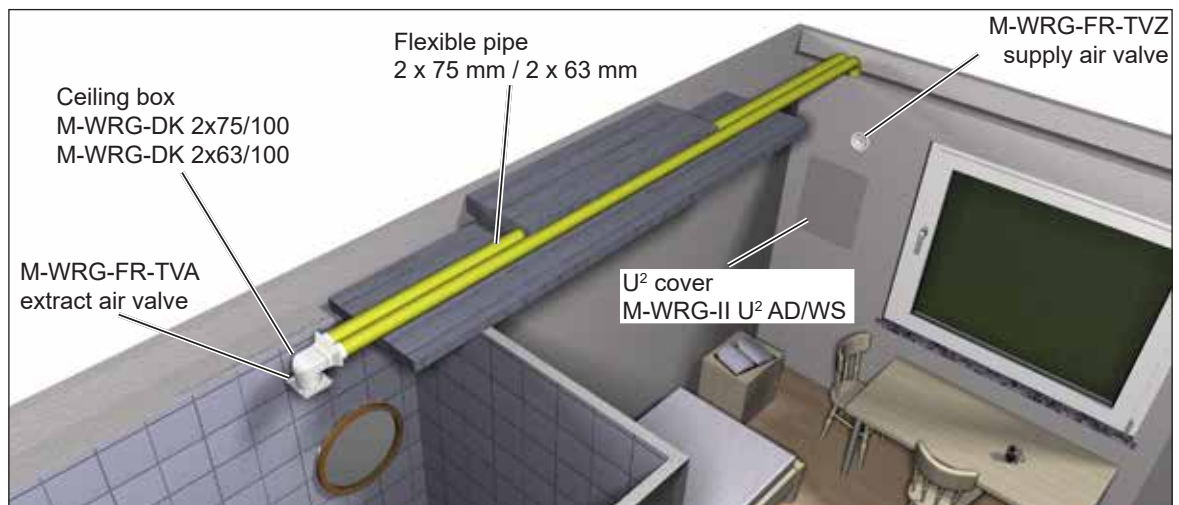

We have checked the content of this publication for conformity with the product described in it. There may nevertheless still be differences, so we cannot guarantee complete accuracy.

The information in this publication is regularly checked and any necessary corrections are made in subsequent editions.

Copyright © Meltem Wärmerückgewinnung GmbH & Co. KG

We reserve the right to make changes.

Meltem Wärmerückgewinnung GmbH & Co. KG

Am Hartholz 4

D-82239 Alling

Germany

Tel. +49 8141 404179-0

Fax +49 8141 404179-9

Internet: www.meltem.com

Email: info@meltem.com



Go to
Meltem download area